

IBC

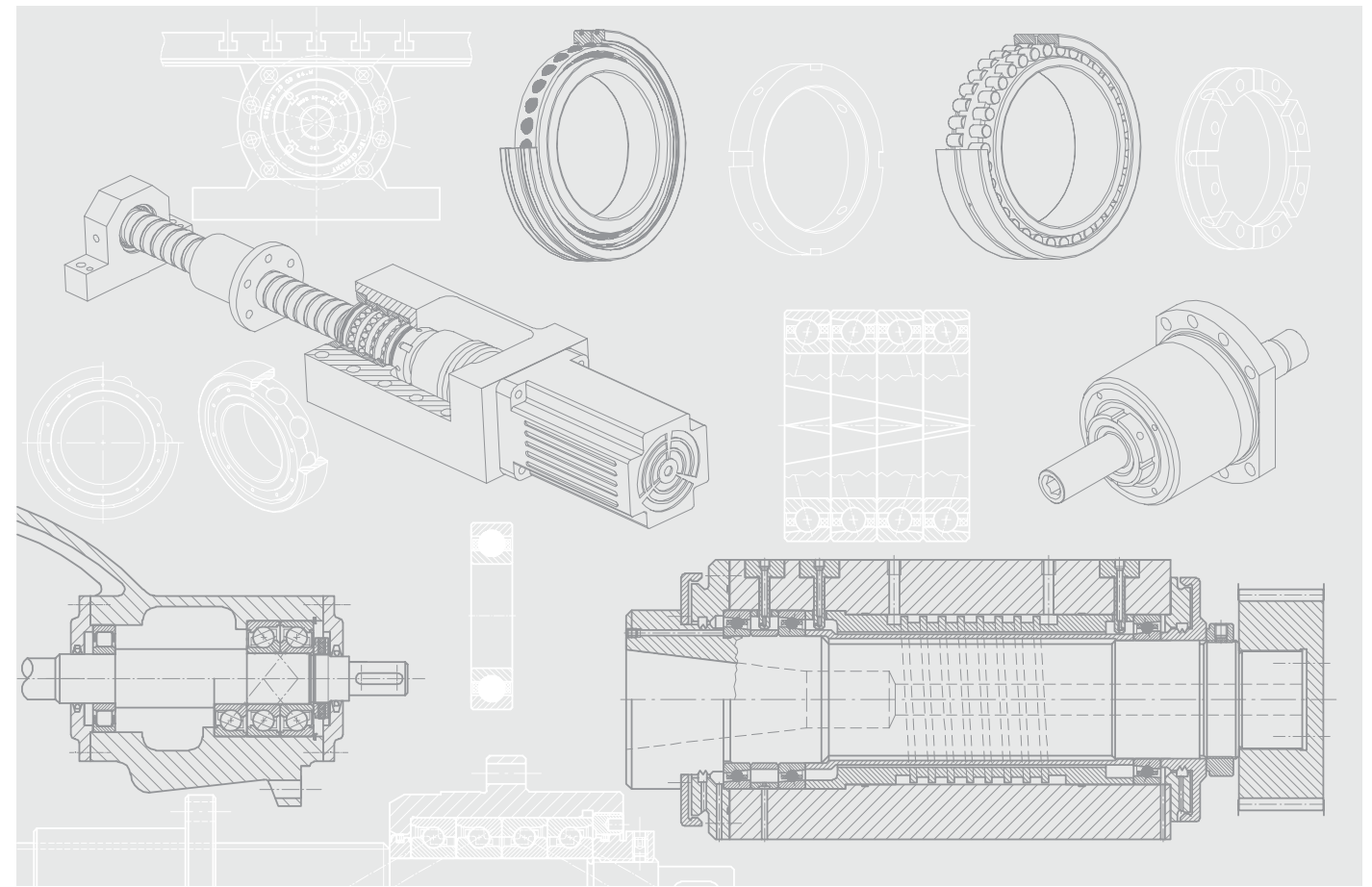

IBC WÄRLZLAGER GMBH INDUSTRIAL BEARINGS AND COMPONENTS

Post box 1825 · 35528 WETZLAR (GERMANY)

Tel: +49/64 41/95 53-02
Fax: +49/64 41/5 30 15



Corporate office
Industriegebiet Oberbiel
D-35606 Solms-Oberbiel

e-mail: ibc@ibc-waelzlager.com

<http://www.ibc-waelzlager.com>

IBC INDUSTRIAL BEARINGS AND COMPONENTS AG

Tel: +41/32/6 52 83 53
Fax: +41/32/6 52 83 58



Corporate office
Kapellstrasse 26
CH-2540 Grenchen

e-mail: ibc@ibcag.ch

<http://www.ibc-waelzlager.com>

Super Precision Bearings

Service Catalog

TI-I-5003.2 / E





Headquarter of the IBC Wälzlager GmbH at the industrial area of Solms-Oberbiel

Location with Tradition

The headquarters in Solms-Oberbiel is centrally located in Germany close to the North/South and East/West highways which also provides for a central location in Europe. The international Airport Frankfurt approx. 80 km away serves as a worldwide link.



Precise Logistics provide an unequalled worldwide reliability

Flexible and Reliable

In the middle of 1996 we opened the central computer controlled high shelf warehouse with more than 2.000 pallet places. It is used for finished and semi-finished products as well as for large bearings. This is in addition to our existing two-storage computer controlled service warehouse also with more than 2.500 storage places. Both warehouse systems provide together with our distribution centre and communication network precise logistics and a worldwide unequalled reliability.



Central Computer Controlled High Shelf Warehouse – Middle 1996



New plant in Asslar

Precision with Future...

We are future orientated. We have the creativity and vision to perform and provide. **This is our exact presentation to solutions with precision.**



More of IBC ...



Company Profile
(German)
(English)



Product Range
Super Precision Bearings
TI-I-5000.0 / D (German)
TI-I-5000.0 / E (English)

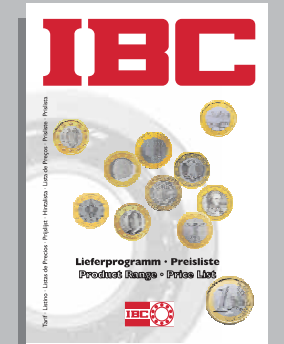

Product Range
Price List



Angular Contact Ball
Bearings 40°
TI-I-4044.0 / D (German)
TI-I-4044.0 / E (English)



Linear Bearings
TI-I-7001.2 / D (German)



Telescopic Rails
TI-I-7005.1 / D (German)



Ball Screw Support Bearings
TI-I-5010.2 / D (German)
TI-I-5010.2 / E (English)



Super Precision Bearings
Service Catalog
TI-I-5003.1 / D (German)
TI-I-5003.2 / E (English)



ATCoated Bearings
TI-I-5010.2 / D (German)

1. Introduction

Permanent increase in demands on quality bearing systems is leading on to new developments of various technologies and new materials, to meet the high and very specific technical and economical fields of application. IBC is taking responsibility for this fact by continuous increase in performance of products and technical processes, as well as extension of product range.

IBC Wälzlager GmbH Industrial Bearings and Components, has more than 30 years experience in the field of bearing technologie. IBC continues the tradition of the 1918 founded Robert Kling Wetzlar GmbH.

Close customer contacts based on fair dialogues and partnership achieve common aims and objectives together with our customers.

The very intensive cooperation with universities, not only in the field of research and development, but also practical job training is a traditional and essential part of the scientific work of IBC Wälzlager GmbH.

The innovation is reflected in the intensive activities of research and development. As an example we point out the material variation of bearing components as a contributing factor to increase the efficiency of our products. This combination of research and controlled processes is leading to high precision bearings.

At the very first beginning special applications have been the cause of hybrid ball bearings, and nowadays these belong to our standard programme for the machine tool and electric motor industry.

Modified materials for cages, as PEEK are used for high-speed precision bearings and for high temperature applications.

Lubricated high precision bearings, completed with sealed versions allow for maintenance free operation with lifetime lubrication. This makes a valuable contribution towards easy mounting and design.

The IBC Wälzlager GmbH delivery programme is enhanced by ATCoat thin dense chromium coated high precision bearings for special applications. Prolongation of usage, reduced wear and friction as well as reasonable corrosion protection are the main value-added benefits of ATCoat high precision bearings.

The following pages of this catalogue are showing the variety of products of high precision angular contact ball bearings (spindle bearings), high precision cylindrical roller bearings, high precision single row deep groove ball bearings, completed by precision rolling bearings of special design, i. e. for turbo charger bearings, compressors, separators and vacuum pumps.

Depending on application high precision angular contact ball bearings can be delivered with contact angle 15°, 25°, 30°, 35°, 40° or 60°, with different diameters of balls out of steel or ceramic, open or sealed. Direct lubrication by the outer ring is another possible variation.

The most convenient bearings can be chosen depending on the requirements regarding rotational speed, load capacity, rigidity, and lubrication as well as any further surrounding parameters.

Many different and innovative principles granting a safe floating bearing function can be found in IBC's product range. Not only high precision cylindrical roller bearings with its constructive floating function, but also the spring loaded high precision deep groove ball bearings and high precision angular contact ball bearings are worth mentioning. Bearings with ATCoat are representing an alternative to avoid fretting corrosion and to grant a slide fit.

Further components of the bearing systems like precision locknuts and labyrinth seals are essential parts of the IBC's delivery programme for many years. They are mainly used for preloading of spindle and ball screw support bearings. A large variety of designs and dimensions implies an optimization of economical efficiency for the users.

Further more IBC is producing an extensive programme of precision flange and pillow block units. In addition to the standard design IBC is offering a large number of special customized solutions.

Our quality management system is implemented and accredited according DIN EN ISO 9001: 2000 for design, development, production and sales of all kinds of rolling bearings and linear motion bearings.

For any further details regarding the different bearing systems as well as how to select the right bearing for safe integration in your individual design, please refer to our corresponding catalogues and brochures. An overview is indicated on the last page.

With this extensive delivery programme, you will find an appropriate IBC high precision bearing for your special application. For further details, our technical department is pleased to be of your assistance and support at any time.

2. IBC Precision Products

Series

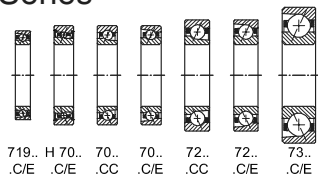

719.. H 70.. 70.. 70.. 72.. 72.. 73..
.C/E .C/E .CC .C/E .CC .C/E .C/E

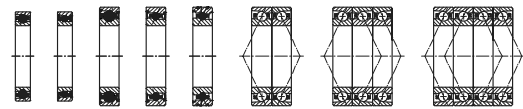

CB CBH CB CBH CBH
719.. 719.. 70.. 70.. 70..S..

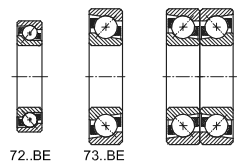

72..BE 73..BE

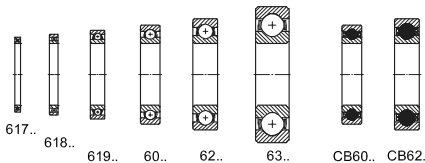

617.. 618.. 619.. 60.. 62.. 63.. CB60.. CB62..

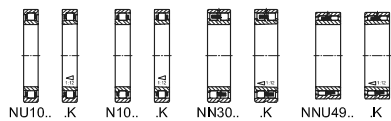

NU10.. .K N10.. .K NN30.. .K NNU49.. .K



511.. 512..

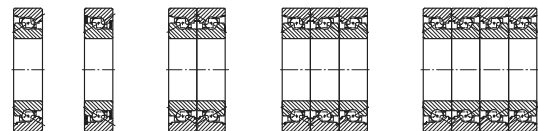

BS..M.. ..2RSZ..

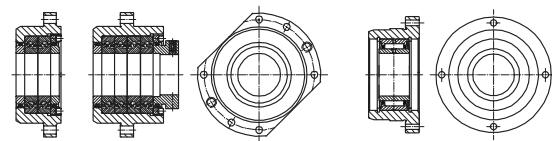

BSPB..DB.. BSPB..M..QB.. BLPB..N...2RS

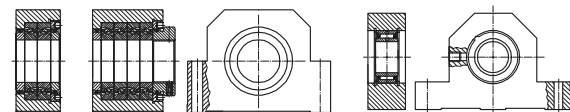

BSPB..D.. BSPB..M..Q.. BLPB..N...2RS

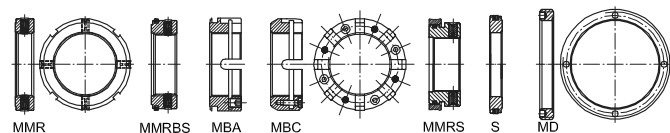

MMR MMRBS MBA MBC MMRS S MD

Designation

Page

Super Precision Angular Contact
Ball Bearings (Spindle Bearings)

5

Hybrid Bearings
Coated Bearings
Matched Sets of Bearings

7

40° Angular Contact Ball Bearings

19

Single Row Deep Groove Ball Bearings

24

Super Precision Cylindrical Roller Bearings

30

Thrust Ball Bearings

40

60° Super Precision Angular Contact
Thrust Ball Bearings

44

Super Precision Bearing Units with 60°
Angular Contact Thrust Ball Bearings and
Floating End Supporting Units

49

Super Precision Pillow Block Bearing Units

52

Super Precision Locknuts and Labyrinth Seals

59

ATCoated Bearings; Cage versions

65

Tolerances, Gradings, Fits, BearLub Greases

68

3. Designation of IBC Super Precision Angular Contact Ball Bearings

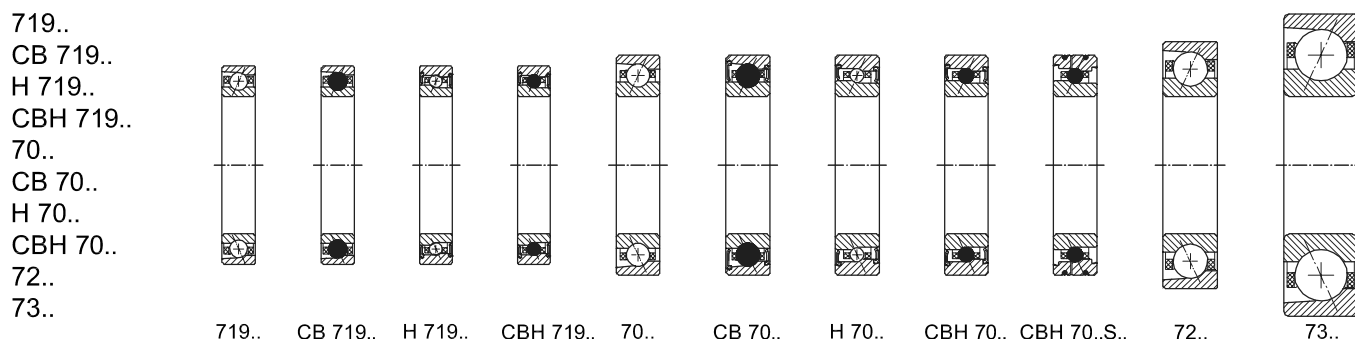

51-102

70	14	.	E	S	.	T	.	P2A.	UL
70	16	.	E	.	.	T	.	P4A. X5	.QBTM. GS32.V...
719	10	.	E	.	.	T	.	P4A. X7	.UM . GS34
CB H	70	12	.	C	.	T	.	2RSZ .P2H. X6	.UL
AC-	72	13	.	E	.	M	.	P4A. X2	.U40 .A11
CB H	719	16	.	E	.	T	.	P2H. X5	.UL

Material	
-	Steel balls 100 Cr6
CB	Ceramic balls Si ₃ N ₄
AC-	Rings ATCoated
ACC-	Rings ATCoated + balls Si ₃ N ₄

Design	
-	Standard design version B
H	High speed design version C

Series	
719.. 72..	
70.. 73..	

Bore code	
00	10 mm 02 15 mm
01	12 mm 03 17 mm
At number 04 and upward x 5 [mm]	

Contact angle	
C	15°
E	25°

Lubrication groove and bore	
S	Lubrication via outer ring

Cage	
T(PA)	Fabric reinforced phenolic resin
M	Solid brass
K	PEEK
S	Stainless steel
P	PA6.6 Polyamide glass fibre reinforced

Special specification	
V..	K..

Lubrication	
-	Corrosion protected
G..	BearLub grease

Coating with ATCoat	
A11	Inner and outer ring ATCoated
A15	Inner and outer ring ATCoated, rolling elements and cage corrosion resistant*
A 21	Inner ring ATCoated
A 31	Outer ring ATCoated

Preload/universally faced bearings	
UX	Extra light
UL	Light
UM	Medium
UH	High
U..	Special preload in daN
A..	Axial clearance with actual value

Bearing arrangements (sets) see page 6

Sorting (bore and O.D.)	
X1, X2, X3, X4, X5, X6, X7, X8, X9	see matrix page 6

Precision	ABEC	ISO	DIN
P4, P4A, P2H, P2A			

Sealing	
2RSZ	Non-contact seal, both sides

Designation system 51-900

*Corrosion protection depending on application, for further information please refer to main catalogue

3.1 Production Range of IBC Precision Angular Contact Ball Bearings

719..
CB 719..
H 719..
CBH 719..
70..
CB 70..
H 70..
CBH 70..
72..
73..

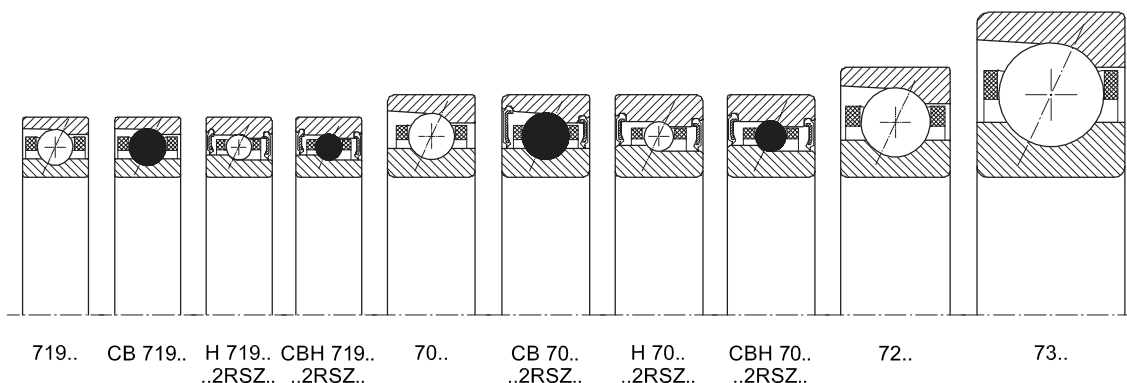

51-112

d mm	Production series																	
	719...			H 719...			70...			H 70...			72...			73...		
	D	B	DI*	D	B	DI*	D	B	DI*	D	B	DI*	D	B	DI*	D	B	DI*
	mm	mm		mm	mm		mm	mm		mm	mm		mm	mm		mm	mm	
10	71900	22	6				7000	26	8				7200	30	9 •			
12	71901	24	6				7001	28	8				7201	32	10 •			
15	71902	28	7				7002	32	9				7202	35	11 •			
17	71903	30	7				7003	35	10				7203	40	12 •			
20	71904	37	9				7004	42	12				7204	47	14 •	7304	52	15
25	71905	42	9 •	H 71905	42	9 •	7005	47	12 •	H 7005	47	12 •	7205	52	15 •	7305	62	17
30	71906	47	9 •	H 71906	47	9 •	7006	55	13 •	H 7006	55	13 •	7206	62	16 •	7306	72	19
35	71907	55	10 •	H 71907	55	10 •	7007	62	14 •	H 7007	62	14 •	7207	72	17 •	7307	80	21
40	71908	62	12 •	H 71908	62	12 •	7008	68	15 •	H 7008	68	15 •	7208	80	18 •	7308	90	23
45	71909	68	12 •	H 71909	68	12 •	7009	75	16 •	H 7009	75	16 •	7209	85	19 •	7309	100	25
50	71910	72	12 •	H 71910	72	12 •	7010	80	16 •	H 7010	80	16 •	7210	90	20 •	7310	110	27
55	71911	80	13 •	H 71911	80	13 •	7011	90	18 •	H 7011	90	18 •	7211	100	21 •	7311	120	29
60	71912	85	13 •	H 71912	85	13 •	7012	95	18 •	H 7012	95	18 •	7212	110	22 •	7312	130	31
65	71913	90	13 •	H 71913	90	13 •	7013	100	18 •	H 7013	100	18 •	7213	120	23	7313	140	33
70	71914	100	16 •	H 71914	100	16 •	7014	110	20 •	H 7014	110	20 •	7214	125	24	7314	150	35
75	71915	105	16 •	H 71915	105	16 •	7015	115	20 •	H 7015	115	20 •	7215	130	25	7315	160	37
80	71916	110	16 •	H 71916	110	16 •	7016	125	22 •	H 7016	125	22 •	7216	140	26			
85	71917	120	18 •	H 71917	120	18 •	7017	130	22 •	H 7017	130	22 •	7217	150	28			
90	71918	125	18 •	H 71918	125	18 •	7018	140	24 •	H 7018	140	24 •	7218	160	30			
95	71919	130	18 •	H 71919	130	18 •	7019	145	24 •	H 7019	145	24 •	7219	170	32			
100	71920	140	20 •	H 71920	140	20 •	7020	150	24 •	H 7020	150	24 •	7220	180	34			
105	71921	145	20	H 71921	145	20	7021	160	26	H 7021	160	26	7221	190	36			
110	71922	150	20	H 71922	150	20	7022	170	28	H 7022	170	28	7222	200	38			
120	71924	165	22	H 71924	165	22	7024	180	28	H 7024	180	28	7224	215	40			
130	71926	180	24				7026	200	33				7226	230	40			
140	71928	190	24				7028	210	33				7228	250	42			
150	71930	210	28				7030	225	35									
160	71932	220	28				7032	240	38									
170	71934	230	28				7034	260	42									
180	71936	250	33				7036	280	46									
190	71938	260	33				7038	290	46									
200	71940	280	38				7040	310	51									
220	71944	300	38															
240	71948	320	38															
260	71952	360	46															
280	71956	380	46															

Table 14-302: Production Range of IBC Precision Angular Contact Ball Bearings

*DI: sealed version

3.2 Arrangements, assorting of Precision Angular Contact Ball Bearings

Sets out of single bearings of same preload (indication of main load in V-direction):

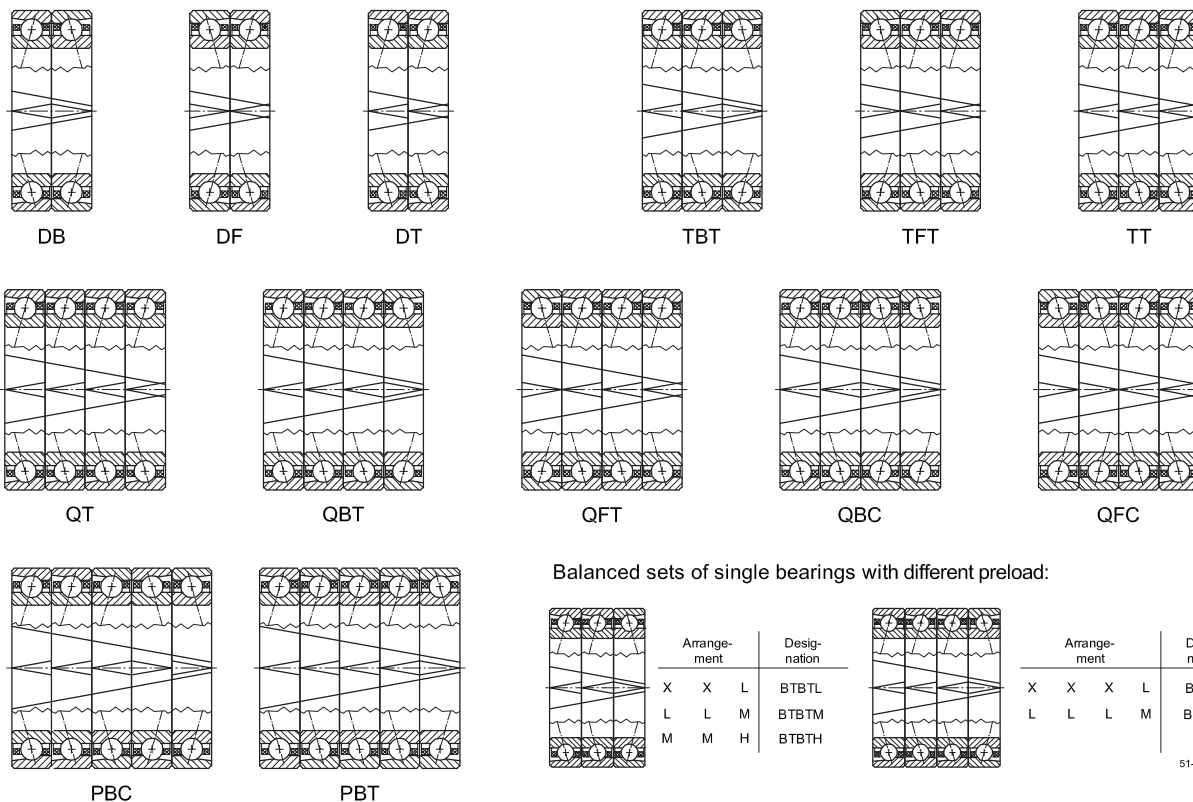

Arrangements, advantages of bearing sets, mounting

According to different needs spindle bearings are used in various arrangements.

IBC supplies single bearings as well as sets with an overall V-marking over the outer rings.

(The V-mark on a single bearing points in the direction, from which side the axial load is applied at the inner ring).

Sets with V-marking are advantageous in several aspects for the customer:

- The diameter tolerance of the inner and outer rings of the bearings is within a selected close tolerance spectrum. (See matrix).
This allows for a more even support of the shafts and housings for the whole set.
It eases the combination with shafts and housings to achieve the same fits for a greater lot.
For fast moving spindles it means a better speed behaviour.
- The V-marking eases the mounting especially with sealed bearings, where the sealing hides the view into the bearing,

which makes it more difficult to put the bearings into the right order based on the main load direction.

The overall V-marking on the set of the outer rings shows the main load direction acting on the inner rings of the set.

- The V-marking also shows the point of highest material thickness or highest radial eccentricity of the outer ring.
- A marked ring at one side face of the bearing shows the highest material thickness or highest radial eccentricity of the inner ring. Even these points should be lined up before mounting.
- A compensation of eccentricities on bearing rings, shaft and housing can be achieved by following before mounting the hints according to c and d in that way that the markings for highest points of the inner rings will be arranged opposite to the smallest diameter of the shaft and at the same time the outer ring markings are in line with the biggest diameter of the housing. Thus enables best running accuracy.

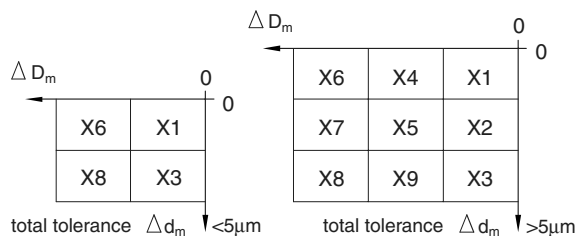

Matrix: combination of arrangement groups for Δd_m and ΔD_m

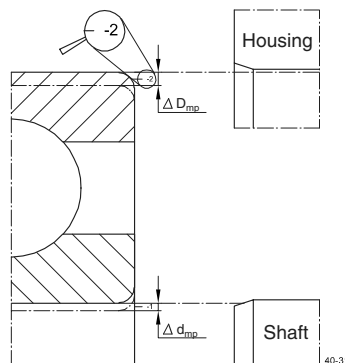

3.3 IBC Super Precision Angular Contact Ball Bearings

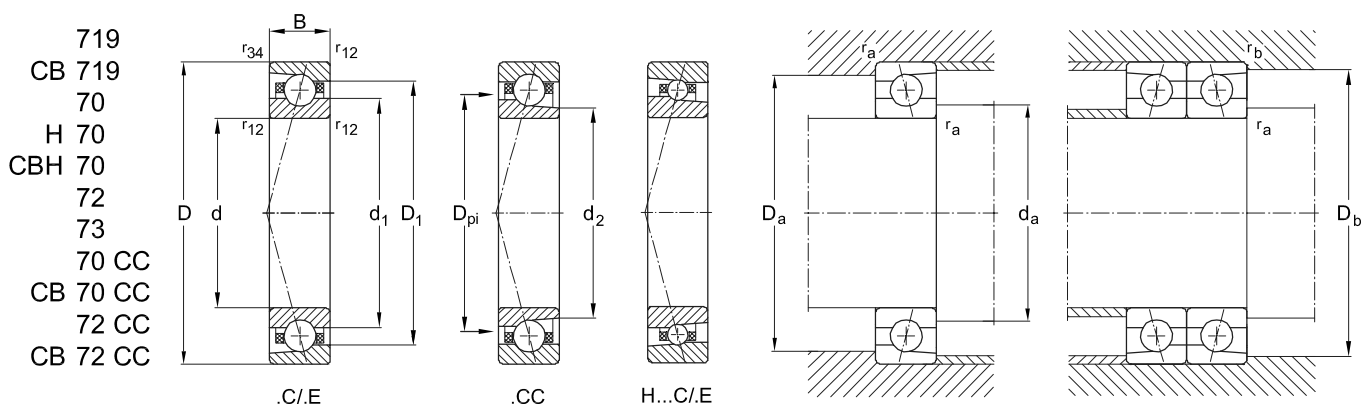

51-601

Primary dimensions			Basic designation	Dimensions				Abutment and fillet dimensions						Weight kg	Precision locknut page 60
d	D mm	B		$r_{12_{min}}$	$r_{34_{min}}$ mm	d_1	D_1	D_{pi}	d_a	D_a	$d_2^{1)/D_b}$ mm	$r_{a_{max}}$	$r_{b_{max}}$		
8	22	7	708 CC	0.3	0.15	12.8	17.5	12.7	11.0	19.5	10.8	0.3	0.15	0.015	MMR 8
9	24	7	709 CC	0.3	0.15	14.3	19.0	14.2	12.5	21.0	12.4	0.3	0.15	0.018	MMR 9
10	22	6	71900	0.3	0.15	14.0	18.1	14.8	12.5	19.5	20.9	0.3	0.15	0.010	MMR 10
10	26	8	CB 7000 CC	0.3	0.15	15.3	21.0	15.2	13.0	23.0	13.0	0.3	0.15	0.019	MMR 10
10	26	8	7000 CC	0.3	0.15	15.3	21.0	15.2	13.0	23.0	13.0	0.3	0.15	0.020	MMR 10
10	26	8	7000	0.3	0.15	14.7	21.4	16.5	12.0	22.7	24.0	0.3	0.15	0.019	MMRB 10
10	30	9	CB 7200 CC	0.6	0.3	17.3	23.0	16.3	14.5	25.5	15.0	0.6	0.3	0.028	MMR 10
10	30	9	7200 CC	0.6	0.3	17.3	23.0	16.3	14.5	25.5	15.0	0.6	0.3	0.030	MMR 10
12	24	6	71901	0.3	0.15	15.8	20.2	16.7	14.5	21.5	22.7	0.3	0.15	0.011	MMR 12
12	28	8	CB 7001 CC	0.3	0.15	17.3	23.0	17.2	15.0	25.0	15.0	0.3	0.15	0.024	MMR 12
12	28	8	7001 CC	0.3	0.15	17.3	23.0	17.2	15.0	25.0	15.0	0.3	0.15	0.025	MMR 12
12	28	8	7001	0.3	0.15	16.7	23.4	18.5	14.0	24.7	26.0	0.3	0.15	0.020	MMRB 12
12	32	10	CB 7201 CC	0.6	0.3	19.3	25.0	18.4	16.5	27.5	16.8	0.6	0.3	0.038	MMR 12
12	32	10	7201 CC	0.6	0.3	19.3	25.0	18.4	16.5	27.5	16.8	0.6	0.3	0.040	MMR 12
12	32	10	7201	0.6	0.3	18.3	26.1	20.4	15.0	27.9	29.0	0.6	0.3	0.035	MMRB 12
15	28	7	71902	0.3	0.15	19.2	23.8	20.3	17.5	25.5	26.7	0.3	0.15	0.016	MMR 15
15	32	9	CB 7002 CC	0.3	0.15	20.8	26.5	20.7	18.5	28.5	18.5	0.3	0.15	0.028	MMR 15
15	32	9	7002 CC	0.3	0.15	20.8	26.5	20.7	18.5	28.5	18.5	0.3	0.15	0.030	MMR 15
15	32	9	7002	0.3	0.15	20.2	26.9	21.9	17.0	28.2	30.0	0.3	0.15	0.029	MMRB 15
15	35	11	CB 7202 CC	0.6	0.3	22.3	28.0	21.3	19.5	28.2	30.0	0.6	0.3	0.048	MMR 15
15	35	11	7202 CC	0.6	0.3	22.3	28.0	21.3	19.5	30.5	19.8	0.6	0.3	0.050	MMR 15
15	35	11	7202	0.6	0.3	21.1	29.1	23.4	18.0	31.0	32.0	0.6	0.3	0.043	MMRB 15
17	30	7	CB 71903	0.3	0.15	20.8	26.3	22.2	19.0	27.5	28.0	0.3	0.15	0.016	MMR 17
17	30	7	71903	0.3	0.15	20.8	26.3	22.2	19.0	27.5	28.0	0.3	0.15	0.017	MMR 17
17	35	10	CB 7003 CC	0.3	0.15	22.9	29.5	23.1	21.0	31.0	20.2	0.3	0.15	0.037	MMR 17
17	35	10	7003 CC	0.3	0.15	22.9	29.5	23.1	21.0	31.0	20.2	0.3	0.15	0.040	MMR 17
17	35	10	7003	0.3	0.15	22.7	29.4	24.4	19.0	30.7	33.0	0.3	0.15	0.039	MMRB 17
17	40	12	CB 7203 CC	0.6	0.3	25.4	32.0	24.3	22.5	34.5	22.4	0.6	0.3	0.067	MMR 17
17	40	12	7203 CC	0.6	0.3	25.4	32.0	24.3	22.5	34.5	22.4	0.6	0.3	0.070	MMR 17
17	40	12	7203	0.6	0.3	24.1	33.0	26.5	20.0	35.0	37.0	1.0	0.3	0.063	MMRB 17
20	37	9	CB 71904	0.3	0.15	25.3	31.8	26.7	22.0	33.5	35.0	0.3	0.15	0.034	MMR 20
20	37	9	71904	0.3	0.15	25.3	31.8	26.7	22.0	33.5	35.0	0.3	0.15	0.036	MMR 20
20	42	12	CB 7004 CC	0.6	0.3	27.0	35.5	27.5	25.0	37.0	23.4	0.6	0.3	0.065	MMR 20
20	42	12	7004 CC	0.6	0.3	27.0	35.5	27.5	25.0	37.0	23.4	0.6	0.3	0.070	MMR 20
20	42	12	7004	0.6	0.3	26.6	35.5	29.0	23.0	37.8	39.0	0.6	0.3	0.065	MMRB 20
20	47	14	CB 7204 CC	1.0	0.6	29.9	37.5	28.8	26.5	40.5	26.6	1.0	0.6	0.106	MMRB 20
20	47	14	7204 CC	1.0	0.6	29.9	37.5	28.8	26.5	40.5	26.6	1.0	0.6	0.110	MMRB 20
20	47	14	7204	1.0	0.6	29.2	37.9	31.0	25.0	41.8	42.0	1.0	0.6	0.106	MMRB 20
20	52	15	7304	1.0	0.6	29.6	41.1	30.9	25.0	45.3	47.0	1.0	0.6	0.144	MMRB 20

¹⁾ Only valid for CC-Bearings.

Contact angle 15°

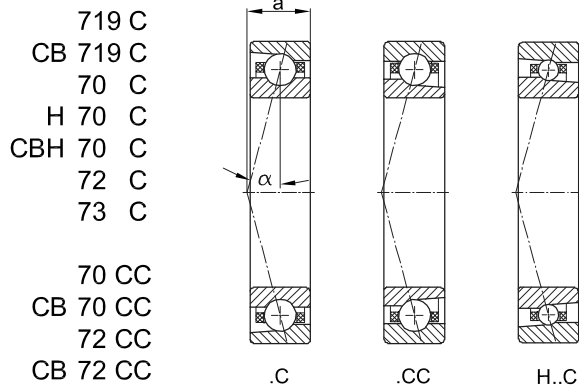

Contact angle 25°

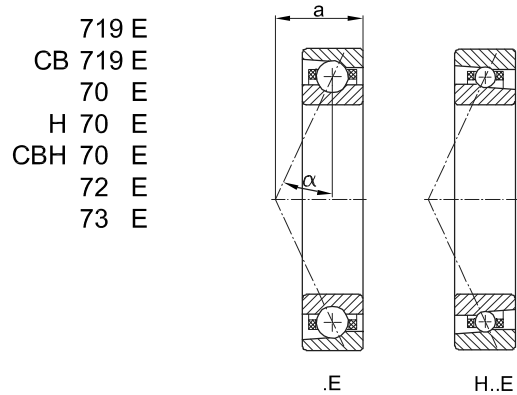

51-113

Basic designation	a mm	Basic load ratings		Speed ratings	
		C N	C ₀	n _b Grease min ⁻¹	Oil-air min ⁻¹
708.CC	5	3 600	1 540	84 000	135 000
709.CC	5	3 900	1 800	79 000	127 000
71900.C	5	3 100	1 600	70 000	111 000
CB 7000.CC	6	4 950	2 250	80 000	145 800
7000.CC	6	4 950	2 250	68 000	108 000
7000.C	6	5 710	2 770	57 000	88 000
CB 7200.CC	7	5 850	2 950	72 500	123 000
7200.CC	7	5 850	2 950	60 800	93 000
71901.C	5	3 300	1 800	60 000	86 000
CB 7001.CC	6	5 450	2 600	72 500	119 000
7001.CC	6	5 450	2 600	57 000	88 000
7001.C	7	6 180	3 180	52 000	80 000
CB 7201.CC	8	6 300	3 450	72 500	106 000
7201.CC	8	6 300	3 450	51 000	79 000
7201.C	8	8 600	4 320	47 000	72 500
71902.C	6	4 700	2 700	50 000	75 000
CB 7002.CC	7	6 300	3 400	61 000	100 000
7002.CC	7	6 300	3 400	48 700	75 000
7002.C	8	6 970	4 010	44 200	68 000
CB 7202.CC	9	6 300	3 450	58 000	94 000
7202.CC	9	6 300	3 450	45 700	70 000
7202.C	9	9 370	5 050	41 600	64 000
CB 71903.C	7	4 740	2 710	59 700	91 800
71903.C	7	4 900	2 900	44 200	68 000
CB 7003.CC	8	8 300	4 550	58 000	90 000
7003.CC	8	8 300	4 550	47 000	75 000
7003.C	9	7 320	4 440	39 600	61 000
CB 7203.CC	10	8 300	4 700	50 800	83 000
7203.CC	10	8 300	4 700	40 000	61 000
7203.C	10	11 600	6 400	36 400	56 000
CB 71904.C	8	6 940	4 240	49 100	75 600
71904.C	8	6 940	4 240	36 400	56 000
CB 7004.CC	9	12 200	6 650	46 000	72 000
7004.CC	9	12 200	6 650	34 700	53 000
7004.C	10	9 830	5 450	33 100	51 000
CB 7204.CC	11	10 600	6 200	43 000	71 000
7204.CC	11	10 600	6 200	34 000	53 000
7204.C	12	13 600	7 250	31 300	48 300
7304.C	12	17 100	8 750	24 700	38 000

Basic designation	a mm	Basic load ratings		Speed ratings	
		C N	C ₀	n _b Grease min ⁻¹	Oil-air min ⁻¹
71900.E	5	2 900	1 500	63 000	96 000
7000.E	8	5 520	2 670	47 400	73 000
71901.E	5	3 100	1 700	57 000	85 000
7001.E	9	5 940	3 070	43 000	66 000
7201.E	10	8 320	4 190	39 200	60 000
71902.E	6	4 500	2 500	49 000	71 000
7002.E	10	6 670	3 830	36 400	56 000
7202.E	12	9 010	4 880	34 800	53 500
CB 71903.E	9	4 510	2 590	49 700	76 300
71903.E	9	4 510	2 900	36 800	56 500
7003.E	11	6 980	4 250	33 700	51 000
7203.E	13	11 100	6 200	31 000	47 700
CB 71904.E	11	6 600	4 050	41 900	64 400
71904.E	11	6 600	4 050	31 000	47 700
7004.E	13	9 400	5 200	29 300	45 100
7204.E	15	13 000	7 000	27 500	42 300
7304.E	16	16 500	8 500	22 300	34 300

3.3 IBC Super Precision Angular Contact Ball Bearings

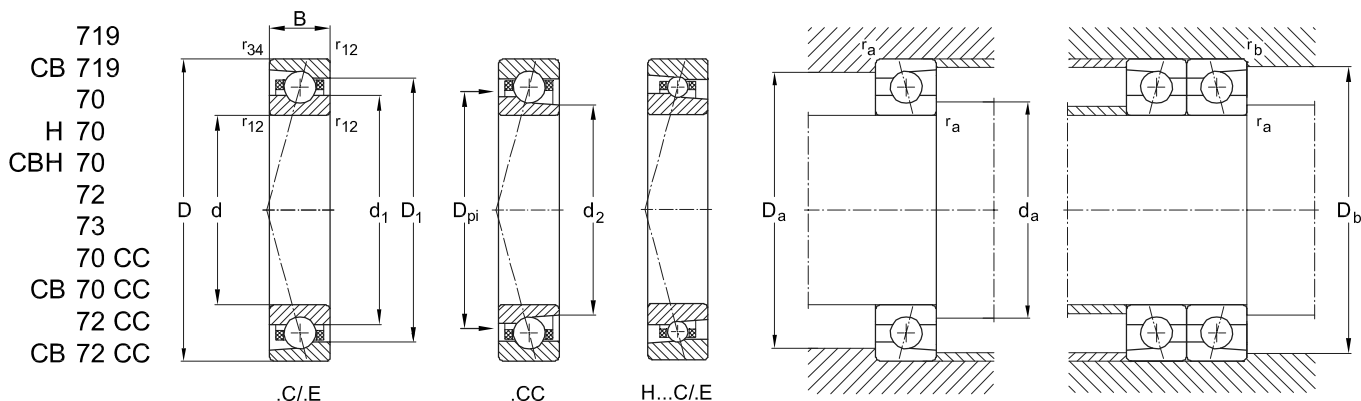

51-601

Primary dimensions			Basic designation	Dimensions				Abutment and fillet dimensions					Weight kg	Precision locknut page 60	
d	D mm	B		$r_{12_{min}}$	$r_{34_{min}}$ mm	d_1	D_1	D_{pi}	d_a	D_a	$d_2^{1)/D_b}$ mm	$r_{a_{max}}$			$r_{b_{max}}$
25	42	9	CB 71905	0.3	0.2	30.3	37.0	31.8	27.0	38.5	40.0	0.3	0.2	0.040	MMR 25
25	42	9	71905	0.3	0.15	30.3	37.0	31.8	27.0	38.5	40.0	0.3	0.15	0.042	MMR 25
25	47	12	CB 7005 CC	0.6	0.3	32.0	40.5	32.5	30.0	42.0	28.5	0.6	0.3	0.074	MMR 25
25	47	12	7005 CC	0.6	0.3	32.0	40.5	32.5	30.0	42.0	28.5	0.6	0.3	0.080	MMR 25
25	47	12	7005	0.6	0.3	32.6	41.3	34.6	28.0	43.5	44.0	0.6	0.3	0.075	MMRB 25
25	52	15	CB 7205 CC	1.0	0.6	34.3	43.0	33.4	31.5	45.5	30.4	1.0	0.6	0.127	MMRB 25
25	52	15	7205 CC	1.0	0.6	34.3	43.0	33.4	31.5	45.5	30.4	1.0	0.6	0.135	MMRB 25
25	52	15	7205	1.0	0.6	34.7	43.3	36.4	30.0	47.0	47.3	1.0	0.6	0.128	MMRB 25
25	62	17	7305	1.0	0.6	38.7	49.9	41.0	30.0	55.0	57.0	1.0	0.6	0.236	MMRB 25
30	47	9	CB 71906	0.3	0.2	35.3	41.8	36.7	32.0	43.5	45.0	0.3	0.2	0.045	MMR 30
30	47	9	71906	0.3	0.15	35.3	41.8	36.7	32.0	43.5	45.0	0.3	0.15	0.048	MMR 30
30	55	13	CB H7006	1.0	0.6	39.6	45.5	40.6	35.0	48.0	50.0	1.0	0.6	0.127	MMRB 30
30	55	13	H7006	1.0	0.6	39.6	45.5	40.6	35.0	48.0	50.0	1.0	0.6	0.130	MMRB 30
30	55	13	7006	1.0	0.6	38.5	46.4	40.1	35.0	49.8	50.0	1.0	0.6	0.118	MMRB 30
30	62	16	7206	1.0	0.6	41.2	51.8	43.3	35.0	56.8	57.0	1.0	0.6	0.197	MMRB 30
30	72	19	7306	1.0	0.6	45.1	59.0	48.1	35.0	65.0	67.0	1.0	0.6	0.348	MMRB 30
35	55	10	CB 71907	0.6	0.3	41.5	48.6	43.2	38.0	50.8	52.0	0.6	0.3	0.071	MMR 35
35	55	10	71907	0.6	0.3	41.5	48.6	43.2	38.0	50.8	52.0	0.6	0.3	0.076	MMR 35
35	62	14	CB H7007	1.0	0.6	45.1	52.0	45.3	40.0	55.0	57.0	1.0	0.6	0.165	MMRB 35
35	62	14	H7007	1.0	0.6	45.1	52.0	45.3	40.0	55.0	57.0	1.0	0.6	0.170	MMRB 35
35	62	14	7007	1.0	0.6	44.5	53.0	46.2	40.0	56.8	57.0	1.0	0.6	0.154	MMRB 35
35	72	17	7207	1.0	0.6	47.9	59.7	50.3	40.0	65.5	67.0	1.0	0.6	0.290	MMRB 35
35	80	21	7307	1.5	0.8	50.5	64.7	53.3	42.5	71.3	72.5	1.5	0.8	0.473	MMRB 35
40	62	12	CB 71908	0.6	0.3	46.7	55.6	49.0	43.0	57.6	59.0	0.6	0.3	0.101	MMR 40
40	62	12	71908	0.6	0.3	46.7	55.6	49.0	43.0	57.6	59.0	0.6	0.3	0.108	MMR 40
40	68	15	CB H7008	1.0	0.6	50.6	57.5	51.8	45.0	60.5	63.0	1.0	0.6	0.214	MMRB 40
40	68	15	H7008	1.0	0.6	50.6	57.5	51.8	45.0	60.5	63.0	1.0	0.6	0.220	MMRB 40
40	68	15	7008	1.0	0.6	49.7	58.5	51.5	45.0	62.3	63.0	1.0	0.6	0.194	MMRB 40
40	80	18	7208	1.0	0.6	53.4	66.8	56.1	45.0	73.3	75.0	1.0	0.6	0.363	MMRB 40
45	68	12	CB 71909	0.6	0.3	52.2	61.1	54.5	48.0	63.3	65.0	0.6	0.3	0.120	MMR 45
45	68	12	71909	0.6	0.3	52.2	61.1	54.5	48.0	63.3	65.0	0.6	0.3	0.128	MMR 45
45	75	16	CB H7009	1.0	0.6	56.1	64.0	57.8	50.0	67.5	70.0	1.0	0.6	0.251	MMRB 45
45	75	16	H7009	1.0	0.6	56.1	64.0	57.8	50.0	67.5	70.0	1.0	0.6	0.260	MMRB 45
45	75	16	7009	1.0	0.6	55.3	64.7	57.2	50.0	69.0	70.0	1.0	0.6	0.245	MMRB 45
45	85	19	7209	1.0	0.6	57.5	72.4	61.0	50.0	78.3	80.0	1.0	0.6	0.408	MMRB 45
50	72	12	CB 71910	0.6	0.3	56.7	65.6	59.0	53.0	67.8	69.0	0.6	0.3	0.121	MMR 50
50	72	12	71910	0.6	0.3	56.7	65.6	59.0	53.0	67.8	69.0	0.6	0.3	0.129	MMR 50
50	80	16	CB H7010	1.0	0.6	61.1	69.0	62.6	55.0	72.5	75.0	1.0	0.6	0.280	MMRB 50
50	80	16	H7010	1.0	0.6	61.1	69.0	62.6	55.0	72.5	75.0	1.0	0.6	0.290	MMRB 50
50	80	16	7010	1.0	0.6	60.5	69.9	62.3	55.0	74.3	75.0	1.0	0.6	0.264	MMRB 50
50	90	20	7210	1.0	0.6	63.5	76.8	66.1	55.0	83.3	85.0	1.0	0.6	0.476	MMRB 50

¹⁾ Only valid for CC-Bearings.

Contact angle 15°

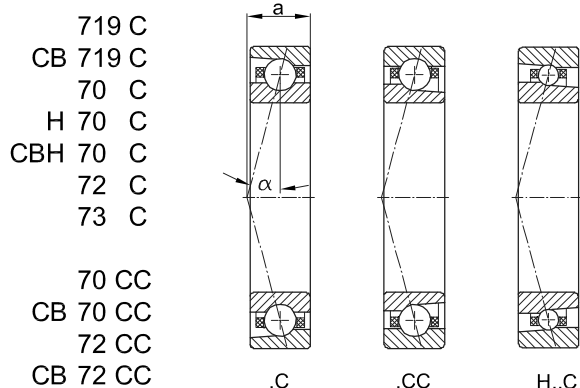

719 C
CB 719 C
70 C
H 70 C
CBH 70 C
72 C
73 C

70 CC
CB 70 CC
72 CC
CB 72 CC

Contact angle 25°

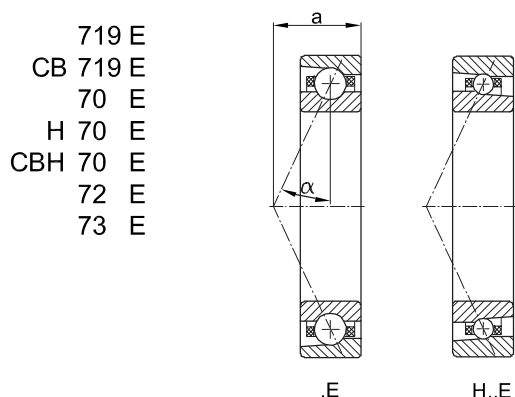

719 E
CB 719 E
70 E
H 70 E
CBH 70 E
72 E
73 E

51-113

Basic designation	a mm	Basic load ratings		Speed ratings	
		C N	C ₀	n _b Grease min ⁻¹	Oil-air min ⁻¹
CB 71905.C	9	7 510	4 400	43 000	65 200
71905.C	9	7 510	5 100	31 400	48 300
CB 7005.CC	10	13 100	6 600	40 300	64 000
7005.CC	10	13 100	7 750	30 700	47 000
7005.C	11	11 700	7 500	29 300	45 200
CB 7205.CC	13	14 300	8 000	37 600	63 000
7205.CC	13	14 300	9 400	30 000	47 000
7205.C	13	14 700	8 550	27 800	42 800
7305.C	14	23 400	13 700	20 300	31 200
CB 71906.C	10	8 000	5 100	37 700	58 100
71906.C	10	8 000	5 950	27 900	43 000
CB H7006.C	12	9 000	5 300	46 800	70 200
H7006.C	12	9 000	7 450	36 000	52 000
7006.C	12	15 100	10 200	26 000	40 000
7206.C	14	23 300	14 400	24 200	37 300
7306.C	16	33 800	20 300	17 200	26 500
CB 71907.C	11	11 000	7 300	33 300	51 300
71907.C	11	11 000	8 550	24 700	38 000
CB H7007.C	14	12 000	7 100	41 600	62 800
H7007.C	14	12 000	10 100	32 000	46 500
7007.C	14	18 300	12 700	23 200	35 800
7207.C	16	30 400	20 100	21 200	32 700
7307.C	18	40 300	25 700	15 100	23 300
CB 71908.C	13	14 000	9 500	30 100	46 300
71908.C	13	14 000	11 100	22 300	34 300
CB H7008.C	15	12 800	8 200	36 400	56 800
H7008.C	15	12 800	11 700	28 000	42 100
7008.C	15	19 700	15 000	21 000	32 400
7208.C	17	36 400	23 800	18 900	29 100
CB 71909.C	14	14 700	10 800	2 700	41 700
71909.C	14	14 700	12 600	20 000	30 900
CB H7009.C	16	15 900	10 300	31 200	50 900
H7009.C	16	15 900	14 600	24 000	37 700
7009.C	16	23 400	18 100	18 800	29 000
7209.C	18	38 600	26 600	17 300	26 700
CB 71910.C	14	14 900	11 400	25 100	38 600
71910.C	14	14 900	13 400	18 600	28 600
CB H7010.C	17	16 600	11 200	28 600	46 800
H7010.C	17	16 600	16 000	22 000	34 700
7010.C	17	24 100	19 500	17 300	26 700
7210.C	20	42 800	31 700	15 700	24 200

Basic designation	a mm	Basic load ratings		Speed ratings	
		C N	C ₀	n _b Grease min ⁻¹	Oil-air min ⁻¹
CB 71905.E	12	7 120	4 100	37 300	57 100
71905.E	12	7 120	4 820	27 500	42 300
7005.E	15	11 100	7 150	26 000	40 000
7205.E	17	14 000	8 150	24 600	37 900
7305.E	19	22 500	13 200	18 300	28 200
CB 71906.E	14	7 550	4 500	33 200	51 200
71906.E	14	7 550	5 600	24 600	37 900
CB H7006.E	17	8 500	4 950	41 600	63 500
H7006.E	17	8 500	7 050	32 000	47 000
7006.E	17	14 400	9 800	22 900	35 200
7206.E	19	22 400	13 900	21 400	33 000
7306.E	22	32 500	19 600	15 600	23 900
CB 71907.E	16	10 400	6 900	29 400	45 200
71907.E	16	10 400	8 100	21 800	33 500
CB H7007.E	19	11 300	6 700	33 800	55 200
H7007.E	19	11 300	9 550	26 000	40 900
7007.E	19	17 400	12 200	20 500	31 500
7207.E	21	29 100	19 100	18 500	28 500
7307.E	24	38 800	24 800	13 700	21 100
CB 71908.E	18	13 200	9 100	26 300	40 500
71908.E	18	13 200	10 600	19 500	30 000
CB H7008.E	20	12 100	8 470	33 200	49 500
H7008.E	20	12 100	11 000	25 500	36 700
7008.E	20	18 700	14 200	18 400	28 300
7208.E	23	34 900	22 800	16 500	25 500
CB 71909.E	19	13 900	10 200	23 800	36 500
71909.E	19	13 900	11 900	17 600	27 000
CB H7009.E	22	15 000	9 700	31 200	44 700
H7009.E	22	15 000	13 800	24 000	33 100
7009.E	22	22 200	17 200	16 500	25 500
7209.E	25	36 900	25 400	15 200	23 500
CB 71910.E	20	14 100	10 800	22 000	33 800
71910.E	20	14 100	12 600	16 300	25 000
CB H7010.E	23	15 600	10 920	26 000	41 200
H7010.E	23	15 600	15 000	20 000	30 500
7010.E	23	22 800	18 600	15 200	23 500
7210.E	27	40 800	30 300	14 000	21 500

3.3 IBC Super Precision Angular Contact Ball Bearings

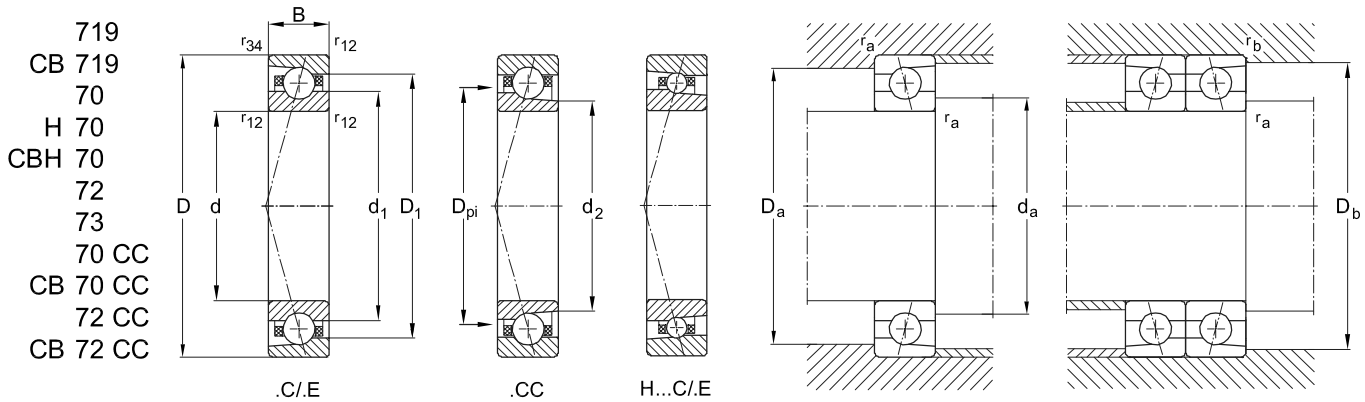

51-601

Primary dimensions			Basic designation	Dimensions				Abutment and fillet dimensions					Weight kg	Precision locknut page 60	
d	D mm	B		$r_{12_{min}}$	$r_{34_{min}}$ mm	d_1	D_1	D_{pi}	d_a	D_a	$D_{b_{max}}$ mm	$r_{a_{max}}$			$r_{b_{max}}$
55	80	13	CB 71911	1.0	0.6	63.7	71.6	65.3	60.0	75.0	75.0	1.0	0.6	0.175	MMR 55
55	80	13	71911	1.0	0.6	63.7	71.6	65.3	60.0	75.0	75.0	1.0	0.6	0.186	MMR 55
55	90	18	CB H7011	1.0	0.6	68.1	77.0	69.7	60.0	80.5	85.0	1.0	0.6	0.416	MMRB 55
55	90	18	H7011	1.0	0.6	68.1	77.0	69.7	60.0	80.5	85.0	1.0	0.6	0.430	MMRB 55
55	90	18	7011	1.0	0.6	67.4	78.5	69.6	60.0	83.8	85.0	1.0	0.6	0.390	MMRB 55
55	100	21	7211	1.5	0.6	70.1	85.0	73.1	62.5	92.5	92.5	1.5	0.6	0.627	MMRB 55
60	85	13	CB 71912	1.0	0.6	68.7	76.6	70.2	65.0	80.0	80.0	1.0	0.6	0.188	MMR 60
60	85	13	71912	1.0	0.6	68.7	76.6	70.2	65.0	80.0	80.0	1.0	0.6	0.200	MMR 60
60	95	18	CB H7012	1.0	0.6	73.1	82.0	74.7	65.0	85.5	90.0	1.0	0.6	0.446	MMRB 60
60	95	18	H7012	1.0	0.6	73.1	82.0	74.7	65.0	85.5	90.0	1.0	0.6	0.460	MMRB 60
60	95	18	7012	1.0	0.6	72.1	83.1	74.2	65.0	88.3	90.0	1.0	0.6	0.418	MMRB 60
60	110	22	7212	1.0	0.8	76.8	93.4	80.1	67.5	101.5	102.5	1.5	0.8	0.795	MMRB 60
65	90	13	CB 71913	1.0	0.6	73.7	81.5	75.2	70.0	85.0	85.0	1.0	0.6	0.201	MMR 65
65	90	13	71913	1.0	0.6	73.7	81.5	75.2	70.0	85.0	85.0	1.0	0.6	0.215	MMR 65
65	100	18	CB H7013	1.0	0.6	78.1	87.0	79.7	70.0	90.5	95.0	1.0	0.6	0.465	MMRB 65
65	100	18	H7013	1.0	0.6	78.1	87.0	79.7	70.0	90.5	95.0	1.0	0.6	0.480	MMRB 65
65	100	18	7013	1.0	0.6	77.2	88.3	79.4	70.0	93.5	95.0	1.0	0.6	0.443	MMRB 65
65	120	23	7213	1.5	0.8	84.4	101.8	87.9	72.5	110.5	112.5	1.5	0.8	1.008	MMRB 65
70	100	16	CB71914	1.0	0.6	80.4	89.8	82.2	75.0	94.3	95.0	1.0	0.6	0.323	MMR 70
70	100	16	71914	1.0	0.6	80.4	89.8	82.2	75.0	94.3	95.0	1.0	0.6	0.345	MMR 70
70	110	20	CB H7014	1.0	0.6	85.2	95.0	87.0	75.0	99.0	105.0	1.0	0.6	0.649	MMRB 70
70	110	20	H7014	1.0	0.6	85.2	95.0	87.0	75.0	99.0	105.0	1.0	0.6	0.670	MMRB 70
70	110	20	7014	1.0	0.6	83.8	96.4	86.3	75.0	102.5	105.0	1.0	0.6	0.617	MMRB 70
70	125	24	7214	1.5	0.8	88.4	106.6	92.0	77.5	115.8	117.5	1.5	0.8	1.107	MMRB 70
75	105	16	CB 71915	1.0	0.6	85.4	94.8	87.2	80.0	99.3	100.0	1.0	0.6	0.343	MMR 75
75	105	16	71915	1.0	0.6	85.4	94.8	87.2	80.0	99.3	100.0	1.0	0.6	0.367	MMR 75
75	115	20	CB H7015	1.0	0.6	90.2	100.1	92.0	80.0	104.0	110.0	1.0	0.6	0.688	MMRB 75
75	115	20	H7015	1.0	0.6	90.2	100.1	92.0	80.0	104.0	110.0	1.0	0.6	0.710	MMRB 75
75	115	20	7015	1.0	0.6	89.1	101.8	91.7	80.0	107.8	110.0	1.0	0.6	0.657	MMRB 75
75	130	25	7215	1.5	0.8	93.4	111.6	97.0	82.5	120.8	122.5	1.5	0.8	1.216	MMRB 75
80	110	16	CB 71916	1.0	0.6	90.4	99.7	92.2	85.0	104.3	105.0	1.0	0.6	0.364	MMR 80
80	110	16	71916	1.0	0.6	90.4	99.7	92.2	85.0	104.3	105.0	1.0	0.6	0.390	MMR 80
80	125	22	CB H7016	1.0	0.6	97.2	108.1	99.2	85.0	112.5	120.0	1.0	0.6	0.931	MMRB 80
80	125	22	H7016	1.0	0.6	97.2	108.1	99.2	85.0	112.5	120.0	1.0	0.6	0.960	MMRB 80
80	125	22	7016	1.0	0.6	95.5	109.7	98.3	85.0	116.8	120.0	1.0	0.6	0.881	MMRB 80
80	140	26	7216	2.0	1.0	101.7	121.5	105.7	90.0	130.0	131.5	2.0	1.0	1.451	MMRB 80

Contact angle 15°

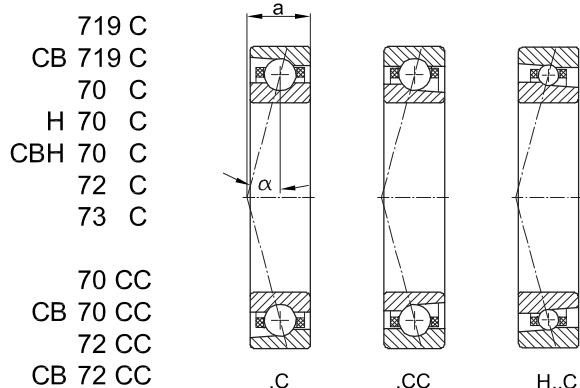

Contact angle 25°

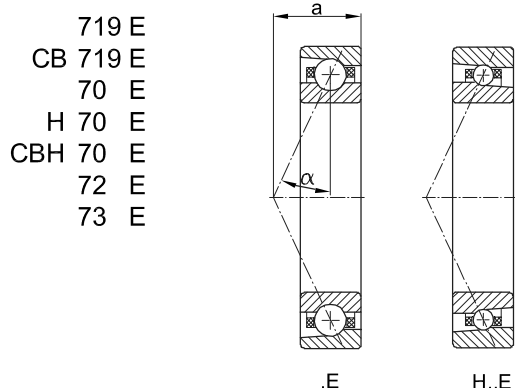

51-113

Basic designation	a mm	Basic load ratings		Speed ratings	
		C N	C ₀	n _b Grease min ⁻¹	Oil-air min ⁻¹
CB 71911.C	16	18 500	14 400	22 400	34 600
71911.C	16	18 500	16 900	16 600	25 600
CB H7011.C	19	20 500	14 200	26 000	41 900
H7011.C	19	20 500	20 200	20 000	31 000
7011.C	19	32 800	27 000	15 400	23 800
7211.C	21	52 900	39 900	14 200	21 900
CB 71912.C	16	19 400	15 900	20 800	32 000
71912.C	16	19 400	18 600	15 400	23 700
CB H7012.C	20	20 800	14 700	24 700	38 300
H7012.C	20	20 800	21 000	19 000	28 400
7012.C	20	33 800	29 000	14 200	21 900
7212.C	23	60 900	45 500	12 800	19 700
CB 71913.C	17	20 200	17 200	19 200	29 600
71913.C	17	20 200	20 200	14 200	21 900
CB H7013.C	20	21 500	15 800	23 400	36 200
H7013.C	20	21 500	22 500	18 000	26 800
7013.C	20	34 700	31 000	13 300	20 600
7213.C	24	66 400	51 000	11 500	17 800
CB 71914.C	19	27 300	22 600	17 300	26 600
71914.C	19	27 300	26 600	12 800	19 700
CB H7014.C	22	26 100	19 500	21 500	32 300
H7014.C	22	26 100	27 800	16 500	23 900
7014.C	22	43 700	38 600	11 900	18 400
7214.C	25	75 800	60 000	10 800	16 700
CB 71915.C	20	28 600	24 700	16 100	24 800
71915.C	20	28 600	29 000	11 900	18 400
CB H7015.C	23	27 000	20 800	20 800	30 200
H7015.C	23	27 000	29 600	16 000	22 400
7015.C	23	46 500	43 500	11 100	17 200
7215.C	26	79 300	64 500	10 100	15 600
CB 71916.C	21	29 800	26 700	15 000	23 200
71916.C	21	29 800	31 400	11 100	17 200
CB H7016.C	25	31 500	24 300	19 500	27 600
H7016.C	25	31 500	34 700	15 000	20 400
7016.C	25	56 700	52 500	10 200	15 700
7216.C	28	88 500	72 500	9 200	14 300

Basic designation	a mm	Basic load ratings		Speed ratings	
		C N	C ₀	n _b Grease min ⁻¹	Oil-air min ⁻¹
CB 71911.E	22	17 500	13 600	19 700	30 400
71911.E	22	17 500	15 900	14 600	22 500
CB H7011.E	26	19 400	13 000	23 400	36 100
H7011.E	26	19 400	18 900	18 000	26 700
7011.E	26	31 100	25 700	13 400	20 600
7211.E	29	50 500	38 200	12 400	19 000
CB 71912.E	23	18 300	14 800	18 100	27 800
71912.E	23	18 300	17 400	13 400	20 600
CB H7012.E	27	19 600	13 800	22 100	33 300
H7012.E	27	19 600	19 600	17 000	24 700
7012.E	27	32 000	27 600	12 400	19 000
7212.E	31	58 100	43 700	11 000	16 900
CB 71913.E	25	19 100	16 000	16 700	25 700
71913.E	25	19 100	18 800	12 400	19 000
CB H7013.E	28	20 200	14 700	19 500	30 600
H7013.E	28	20 200	20 900	15 000	22 700
7013.E	28	32 800	29 400	11 400	17 500
7213.E	33	63 300	48 600	9 600	14 900
CB 71914.E	28	25 700	21 200	14 700	22 700
71914.E	28	25 700	24 900	10 900	16 800
CB H7014.E	31	24 600	18 200	18 200	27 000
H7014.E	31	24 600	25 900	14 000	20 000
7014.E	31	41 400	36 800	10 100	15 500
7214.E	35	72 300	57 500	9 000	13 900
CB 71915.E	29	26 900	23 100	13 600	21 000
71915.E	29	26 900	27 100	10 100	15 500
CB H7015.E	32	25 400	19 400	16 900	25 200
H7015.E	32	25 400	27 600	13 000	18 700
7015.E	32	43 900	41 200	9 300	14 400
7215.E	37	75 400	61 500	8 500	12 600
CB 71916.E	30	28 100	24 900	12 600	19 300
71916.E	30	28 100	29 200	9 300	14 300
CB H7016.E	35	29 600	22 700	16 300	22 400
H7016.E	35	29 600	32 300	12 500	16 600
7016.E	35	53 700	49 900	8 700	12 800
7216.E	39	84 300	69 500	8 200	11 500

3.3 IBC Super Precision Angular Contact Ball Bearings

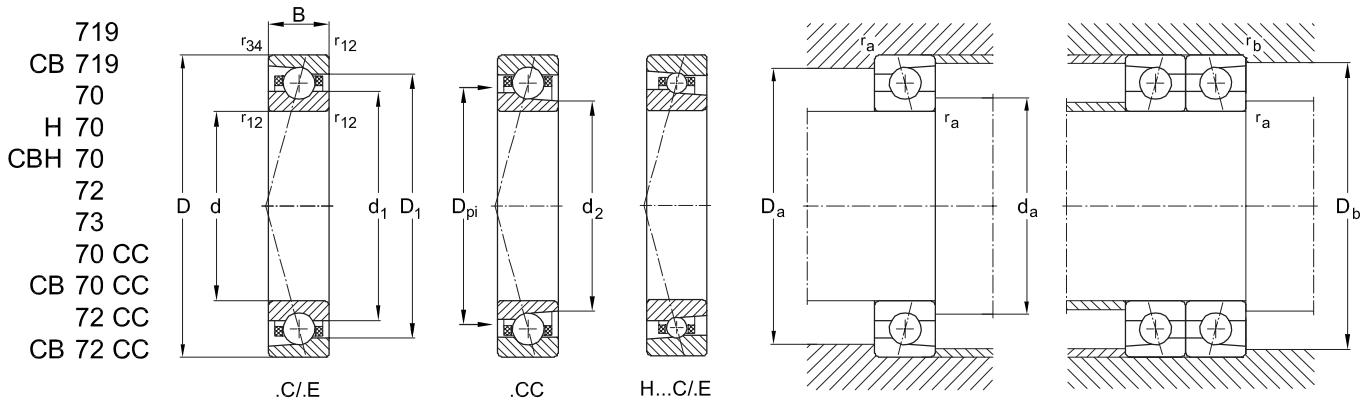

51-601

Primary dimensions			Basic designation	Dimensions				Abutment and fillet dimensions					Weight kg	Precision locknut page 60	
d	D mm	B		$r_{12_{min}}$	$r_{34_{min}}$	d_1	D_1	D_{pi}	d_a	D_a	$D_{b_{max}}$	$r_{a_{max}}$			$r_{b_{max}}$
85	120	18	CB 71917	1.0	0.6	97.1	108.2	99.3	90.0	113.3	115.0	1.0	0.6	0.518	MMR 85
85	120	18	71917	1.0	0.6	97.1	108.2	99.3	90.0	113.3	115.0	1.0	0.6	0.554	MMR 85
85	130	22	CB H7017	1.0	0.6	102.2	113.1	104.2	90.0	117.5	125.0	1.0	0.6	0.989	MMRB 85
85	130	22	H7017	1.0	0.6	102.2	113.1	104.2	90.0	117.5	125.0	1.0	0.6	1.020	MMRB 85
85	130	22	7017	1.0	0.6	101.0	115.3	103.9	90.0	122.3	125.0	1.0	0.6	0.921	MMRB 85
85	150	28	7217	2.0	1.0	107.3	127.9	111.4	95.0	138.3	140.0	2.0	1.0	1.872	MMRB 85
90	125	18	CB 71918	1.0	0.6	102.1	113.1	104.3	95.0	118.3	120.0	1.0	0.6	0.540	MMR 90
90	125	18	71918	1.0	0.6	102.1	113.1	104.3	95.0	118.3	120.0	1.0	0.6	0.581	MMR 90
90	140	24	CB H7018	1.5	0.8	108.7	121.6	111.1	97.5	126.5	132.5	1.5	0.8	1.164	MMRB 90
90	140	24	H7018	1.5	0.8	108.7	121.6	111.1	97.5	126.5	132.5	1.5	0.8	1.210	MMRB 90
90	140	24	7018	1.5	0.8	108.1	123.9	111.2	97.5	131.8	132.5	1.5	0.8	1.189	MMRB 90
90	160	30	7218	2.0	1.0	115.3	136.7	119.6	100.0	147.5	150.0	2.0	1.0	2.336	MMRB 90
95	130	18	CB 71919	1.0	0.6	107.1	118.1	109.3	100.0	123.3	125.0	1.0	0.6	0.573	MMR 95
95	130	18	71919	1.0	0.6	107.1	118.1	109.3	100.0	123.3	125.0	1.0	0.6	0.616	MMR 95
95	145	24	CB H7019	1.5	0.8	113.7	126.6	116.1	102.5	131.5	137.5	1.5	0.8	1.303	MMRB 95
95	145	24	H7019	1.5	0.8	113.7	126.6	116.1	102.5	136.5	137.5	1.5	0.8	1.350	MMRB 95
95	145	24	7019	1.5	0.8	112.9	128.7	116.0	102.5	136.5	137.5	1.5	0.8	1.245	MMRB 95
95	160	32	7219	2.0	1.0	121.3	145.2	126.1	105.0	157.3	160.0	2.0	1.0	2.794	MMRB 95
100	140	20	CB 71920	1.0	0.6	113.8	126.4	116.3	105.0	132.5	135.0	1.0	0.6	0.766	MMR 100
100	140	20	71920	1.0	0.6	113.8	126.4	116.3	105.0	132.5	135.0	1.0	0.6	0.826	MMR 100
100	150	24	CB H7020	1.5	0.8	118.7	131.6	121.1	107.5	136.5	142.5	1.5	0.8	1.349	MMRB 100
100	150	24	H7020	1.5	0.8	118.7	131.6	121.1	107.5	136.5	142.5	1.5	0.8	1.400	MMRB 100
100	150	24	7020	1.5	0.8	117.7	133.5	120.8	107.5	141.3	142.5	1.5	0.8	1.288	MMRB 100
100	180	34	7220	2.0	1.0	127.0	153.2	132.3	110.0	166.5	170.0	2.0	1.0	3.312	MMRB 100
105	145	20	CB 71921	1.0	0.6	118.8	131.4	121.3	110.0	137.5	140.0	1.0	0.6	0.781	MMR 105
105	145	20	71921	1.0	0.6	118.8	131.4	121.3	110.0	137.5	140.0	1.0	0.6	0.844	MMR 105
105	160	26	7021	2.0	1.0	123.9	141.3	127.4	115.0	150.0	150.0	2.0	1.0	1.550	MMRB 105
105	190	36	7221	2.0	1.0	134.3	162.9	140.7	115.0	175.0	180.0	2.0	1.0	3.845	MMRB 105
110	150	20	CB 71922	1.0	0.6	123.8	136.4	126.4	115.0	142.5	145.0	1.0	0.6	0.785	MMR 110
110	150	20	71922	1.0	0.6	123.8	136.4	126.4	115.0	142.5	145.0	1.0	0.6	0.850	MMR 110
110	170	28	AC 7022	2.0	1.0	129.0	151.1	134.4	120.0	159.3	160.0	2.0	1.0	1.990	MMRB 110
110	170	28	7022	2.0	1.0	129.0	151.1	134.4	120.0	159.3	160.0	2.0	1.0	1.990	MMRB 110
110	200	38	7222	2.0	1.0	142.1	170.0	147.7	120.0	184.3	190.0	2.0	1.0	4.710	MMRB 110
120	165	22	CB 71924	1.0	0.6	135.5	149.7	138.3	125.0	156.3	160.0	1.0	0.6	10.070	MMR 120
120	165	22	71924	1.0	0.6	135.5	149.7	138.3	125.0	156.3	160.0	1.0	0.6	1.160	MMR 120
120	180	28	AC 7024	2.0	1.0	140.6	159.6	144.4	130.0	169.3	170.0	2.0	1.0	2.190	MMRB 120
120	180	28	7024	2.0	1.0	140.6	159.6	144.4	130.0	169.3	170.0	2.0	1.0	2.190	MMRB 120
120	215	40	7224	2.0	1.0	153.9	182.8	160.0	130.0	196.8	205.0	2.0	1.0	5.710	MMRB 120
130	180	24	AC 71926	1.0	0.6	147.2	163.0	150.4	137.5	170.8	172.5	1.0	0.6	1.540	MMR 130
130	180	24	71926	1.0	0.6	147.2	163.0	150.4	137.5	170.8	172.5	1.0	0.6	1.540	MMR 130
130	200	33	AC 7026	2.0	1.0	154.4	175.8	158.7	140.0	186.8	190.0	2.0	1.0	3.340	MMRB 130
130	200	33	7026	2.0	1.0	154.4	175.8	158.7	140.0	186.8	190.0	2.0	1.0	3.340	MMRB 130
130	230	40	7226	2.0	1.0	164.8	195.6	170.9	142.5	211.5	217.5	2.5	1.0	6.380	MMRB 130

Contact angle 15°

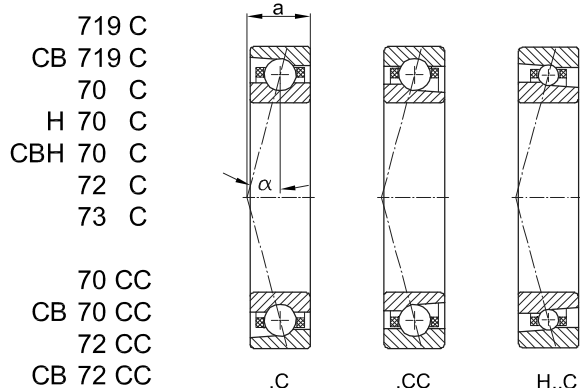

719 C
CB 719 C
70 C
H 70 C
CBH 70 C
72 C
73 C

70 CC
CB 70 CC
72 CC
CB 72 CC

Contact angle 25°

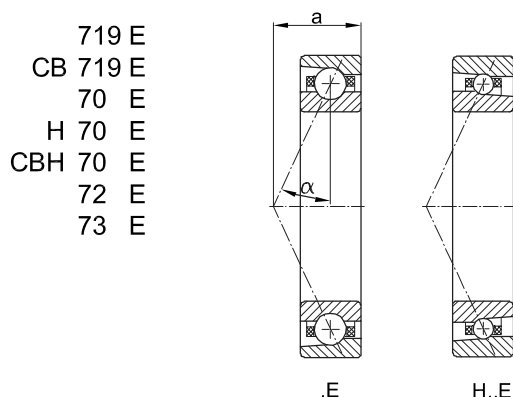

719 E
CB 719 E
70 E
H 70 E
CBH 70 E
72 E
73 E

51-113

Basic designation	a mm	Basic load ratings		Speed ratings	
		C N	C ₀	n _b Grease min ⁻¹	Oil-air min ⁻¹
CB 71917.C	23	36 700	31 600	13 800	21 200
71917.C	23	36 700	37 100	10 200	15 700
CB H7017.C	26	32 500	25 900	18 200	25 800
H7017.C	26	32 500	36 900	14 000	19 100
7017.C	26	58 200	56 000	9 500	14 700
7217.C	30	99 700	84 500	8 500	13 100
CB 71918.C	23	39 600	35 900	12 800	19 800
71918.C	23	39 600	42 200	9 500	14 700
CB H7018.C	28	42 000	32 900	16 300	23 600
H7018.C	28	42 000	47 000	12 500	17 500
7018.C	28	69 100	65 500	9 100	13 500
7218.C	32	112 000	98 000	8 200	12 000
CB 71919.C	24	40 200	37 300	12 400	18 500
71919.C	24	40 200	43 800	9 200	13 700
CB H7019.C	28	42 600	34 000	15 600	22 100
H7019.C	28	42 600	48 500	12 000	16 400
7019.C	28	71 100	70 000	8 900	13 000
7219.C	34	130 000	113 000	8 000	11 800
CB 71920.C	26	50 200	45 900	12 200	18 100
71920.C	26	50 200	54 000	9 000	13 400
CB H7020.C	29	44 100	36 200	14 300	21 100
H7020.C	29	44 100	51 500	11 000	15 600
7020.C	29	70 600	70 000	8 700	12 800
7220.C	36	149 000	127 000	7 800	11 500
CB 71921.C	27	51 100	47 600	11 800	17 300
71921.C	27	51 100	56 000	8 700	12 800
7021.C	31	85 200	85 000	8 200	12 100
7221.C	38	156 000	138 000	7 400	10 900
CB 71922.C	30	52 000	49 800	11 200	16 600
71922.C	30	52 000	58 500	8 300	12 300
AC 7022.C	33	97 500	96 000	8 600	12 900
7022.C	33	97 500	96 000	7 700	11 500
7222.C	40	169 000	156 000	7 000	10 400
CB 71924.C	33	63 900	61 200	10 300	15 300
71924.C	33	63 900	72 000	7 600	11 300
AC 7024.C	34	103 000	108 000	8 100	12 000
7024.C	34	103 000	108 000	7 200	10 700
7224.C	43	176 000	169 000	6 500	9 600
AC 71926.C	34	78 600	90 000	7 800	11 700
71926.C	34	78 600	90 000	7 000	10 400
AC 7026.C	39	125 000	131 000	7 400	10 900
7026.C	39	125 000	131 000	6 600	9 700
7226.C	44	198 000	196 000	6 000	8 900

Basic designation	a mm	Basic load ratings		Speed ratings	
		C N	C ₀	n _b Grease min ⁻¹	Oil-air min ⁻¹
CB 71917.E	33	34 600	29 600	11 600	17 300
71917.E	33	34 600	34 800	8 600	12 800
CB H7017.E	36	30 600	24 100	15 600	20 800
H7017.E	36	30 600	34 400	12 000	15 400
7017.E	36	55 000	53 000	8 400	12 200
7217.E	42	94 900	81 000	7 800	11 000
CB 71918.E	34	37 300	33 500	11 300	16 500
71918.E	34	37 300	39 400	8 400	12 200
CB H7018.E	39	39 600	30 700	14 300	18 800
H7018.E	39	39 600	43 800	11 000	13 900
7018.E	39	65 400	62 500	8 300	11 900
7218.E	44	106 000	94 000	7 500	10 600
CB 71919.E	35	37 900	34 700	11 100	16 100
71919.E	35	37 900	40 800	8 200	11 900
CB H7019.E	40	40 100	31 700	13 000	17 600
H7019.E	40	40 100	45 200	10 000	13 000
7019.E	40	67 200	66 000	7 900	11 500
7219.E	47	124 000	108 000	7 200	10 300
CB 71920.E	38	47 300	43 100	10 800	15 800
71920.E	38	47 300	50 500	7 900	11 500
CB H7020.E	41	41 500	33 800	12 400	16 100
H7020.E	41	41 500	48 200	9 500	11 900
7020.E	41	66 700	66 500	7 700	11 200
7220.E	50	142 000	121 000	6 900	10 000
CB 71921.E	39	48 200	44 700	10 400	15 100
71921.E	39	48 200	52 500	7 700	11 200
7021.E	44	80 500	80 000	7 300	10 600
7221.E	53	148 000	132 000	6 500	9 500
CB 71922.E	40	49 000	46 400	10 000	14 600
71922.E	40	49 000	54 500	7 400	10 800
AC 7022.E	47	92 300	91 500	7 700	11 200
7022.E	47	92 300	91 500	6 900	10 000
7222.E	55	161 000	148 000	6 200	9 100
CB 71924.E	44	60 300	57 500	9 200	13 400
71924.E	44	60 300	67 500	6 800	9 900
AC 7024.E	49	97 400	102 000	7 200	10 500
7024.E	49	97 400	102 000	6 400	9 400
7224.E	60	167 000	162 000	5 800	8 400
AC 71926.E	48	74 100	84 500	6 900	10 200
71926.E	48	74 100	84 500	6 200	9 100
AC 7026.E	55	118 000	124 000	6 600	9 500
7026.E	55	118 000	124 000	5 900	8 500
7226.E	62	188 000	187 000	5 400	7 800

3.3 IBC Super Precision Angular Contact Ball Bearings

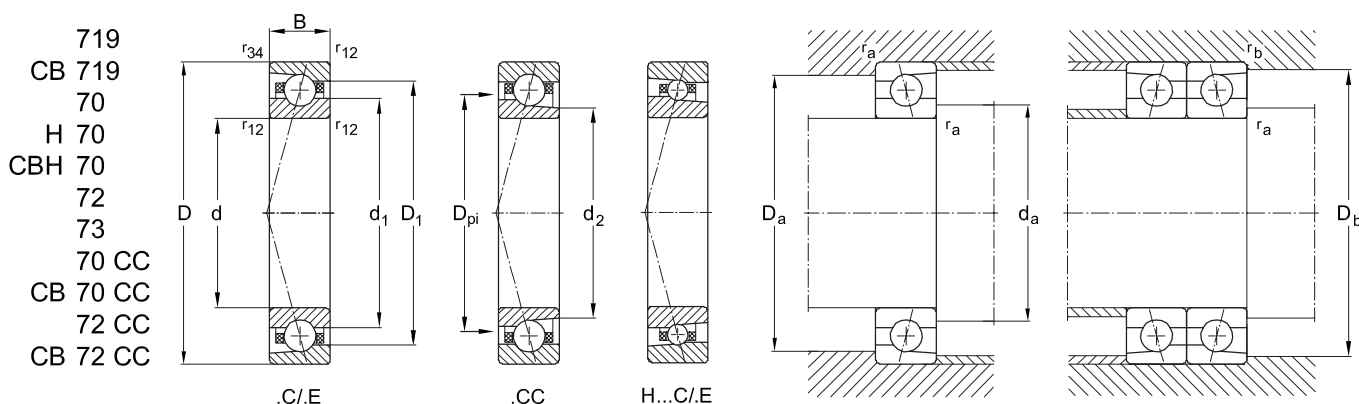

51-601

Primary dimensions			Basic designation	Dimensions				Abutment and fillet dimensions					Weight kg	Precision locknut page 61	
d	D mm	B		$r_{12_{min}}$	$r_{34_{min}}$	d_1	D_1	D_{pi}	d_a	D_a	$D_{b_{max}}$	$r_{a_{max}}$			$r_{b_{max}}$
140	190	24	AC 71928	1.5	0.8	157.2	173.0	160.3	147.5	182.5	180.8	1.5	0.8	1.620	MMR 140
140	190	24	71928	1.5	0.8	157.2	173.0	160.3	147.5	182.5	180.8	1.5	0.8	1.620	MMR 140
140	210	33	AC 7028	2.0	1.0	164.4	185.8	168.7	150.0	200.0	196.8	2.0	1.0	3.570	MMRB 140
140	210	33	7028	2.0	1.0	164.4	185.8	168.7	150.0	200.0	196.8	2.0	1.0	3.570	MMRB 140
140	250	42	7228	2.5	1.5	177.0	212.7	185.1	152.5	237.5	228.3	2.5	1.5	8.020	MMRB 140
150	210	28	AC 71930	1.5	0.8	170.6	189.6	174.4	160.0	200.0	199.0	2.0	0.8	2.540	MMR 150
150	210	28	71930	1.5	0.8	170.6	189.6	174.4	160.0	200.0	199.0	2.0	0.8	2.540	MMR 150
150	225	35	AC 7030	2.0	1.0	176.2	199.1	180.7	160.0	215.0	211.0	2.0	1.0	4.320	MMRB 150
150	225	35	7030	2.0	1.0	176.2	199.1	180.7	160.0	215.0	211.0	2.0	1.0	4.320	MMRB 150
150	270	45	7230	2.5	1.5	193.9	226.4	200.3	162.5	257.5	243.3	2.5	1.5	10.320	MMRB 150
160	220	28	AC 71932	2.0	1.0	180.6	199.6	184.4	170.0	210.0	209.0	2.0	1.0	2.670	MMR 160
160	220	28	71932	2.0	1.0	180.6	199.6	184.4	170.0	210.0	209.0	2.0	1.0	2.670	MMR 160
160	240	38	AC 7032	2.0	1.0	187.8	212.4	192.7	170.0	230.0	225.0	2.0	1.0	5.190	MMRB 160
160	240	38	7032	2.0	1.0	187.8	212.4	192.7	170.0	230.0	225.0	2.0	1.0	5.190	MMRB 160
170	230	28	AC 71934	2.0	1.0	190.6	209.6	194.4	180.0	220.0	219.0	2.0	1.0	2.810	MMR 170
170	230	28	71934	2.0	1.0	190.6	209.6	194.4	180.0	220.0	219.0	2.0	1.0	2.810	MMR 170
170	260	42	AC 7034	2.0	1.0	201.2	229.1	206.8	180.0	250.0	243.5	2.0	1.0	6.950	MMRB 170
170	260	42	7034	2.0	1.0	201.2	229.1	206.8	180.0	250.0	243.5	2.0	1.0	6.950	MMRB 170
180	250	33	AC 71936	2.0	1.0	204.4	225.8	208.6	190.0	240.0	236.5	2.0	1.0	4.230	MMR 180
180	250	33	71936	2.0	1.0	204.4	225.8	208.6	190.0	240.0	236.5	2.0	1.0	4.230	MMR 180
180	280	46	AC 7036	2.0	1.0	215.4	244.8	221.3	190.0	270.0	260.0	2.0	1.0	9.100	MMRB 180
180	280	46	7036	2.0	1.0	215.4	244.8	221.3	190.0	270.0	260.0	2.0	1.0	9.100	MMRB 180
190	260	33	AC 71938	2.0	1.0	214.4	235.8	218.7	200.0	250.0	246.5	2.0	1.0	4.350	MMR 190
190	260	33	71938	2.0	1.0	214.4	235.8	218.7	200.0	250.0	246.5	2.0	1.0	4.350	MMR 190
190	290	46	AC 7038	2.0	1.0	225.4	254.5	231.1	200.0	280.0	270.0	2.0	1.0	9.800	MMRB 190
190	290	46	7038	2.0	1.0	225.4	254.5	231.1	200.0	280.0	270.0	2.0	1.0	9.800	MMRB 190
200	280	38	AC 71940	2.0	1.0	227.8	252.4	232.7	210.0	270.0	265.0	2.0	1.0	6.250	MMR 200
200	280	38	71940	2.0	1.0	227.8	252.4	232.7	210.0	270.0	265.0	2.0	1.0	6.250	MMR 200
200	310	51	AC 7040	2.0	1.0	238.9	271.4	245.3	210.0	300.0	288.5	2.0	1.0	12.300	MMRB 200
200	310	51	7040	2.0	1.0	238.9	271.4	245.3	210.0	300.0	288.5	2.0	1.0	12.300	MMRB 200
220	300	38	AC 71944	2.0	1.0	247.8	272.5	252.8	230.0	290.0	285.0	2.0	1.0	6.580	MMR 220
220	300	38	71944	2.0	1.0	247.8	272.5	252.8	230.0	290.0	285.0	2.0	1.0	6.580	MMR 220
240	320	38	AC 71948	2.0	1.0	267.8	292.4	272.7	250.0	310.0	305.0	2.0	1.0	7.100	MMR 240
240	320	38	71948	2.0	1.0	267.8	292.4	272.7	250.0	310.0	305.0	2.0	1.0	7.100	MMR 240
260	360	46	71952	2.0	1.0	295.4	324.9	301.1	272.0	345.0	348.0	2.0	1.0	7.800	MMR 260
280	380	46	71956	2.0	1.0	315.4	344.9	321.1	292.0	365.0	368.0	2.0	1.0	8.800	MMR 280

Contact angle 15°

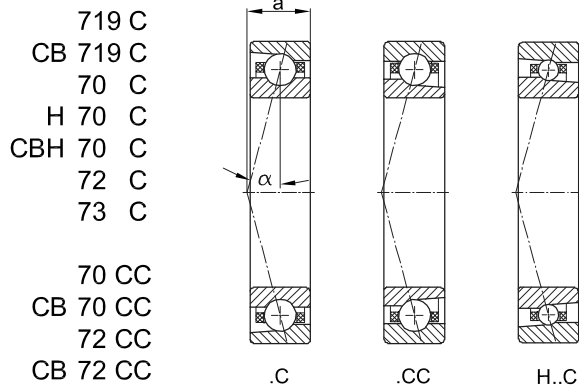

Contact angle 25°

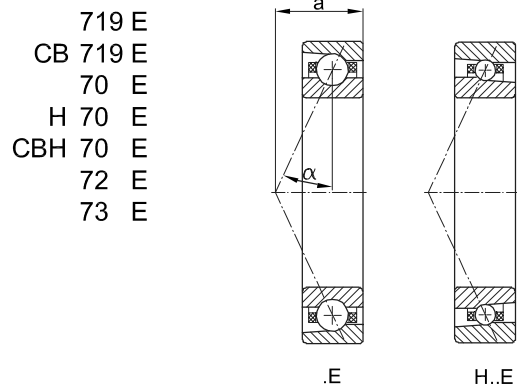

51-113

Basic designation	a mm	Basic load ratings		Speed ratings	
		C N	C ₀	n _b Grease min ⁻¹	Oil-air min ⁻¹
AC 71928.C	38	79 600	93 500	7 400	10 900
71928.C	38	79 600	93 500	6 600	9 700
AC 7028.C	40	132 000	145 000	6 900	10 300
7028.C	40	132 000	145 000	6 200	9 200
7228.C	47	212 000	219 000	5 600	8 000
AC 71930.C	40	112 000	132 000	6 700	10 000
71930.C	40	112 000	132 000	6 000	8 900
AC 7030.C	43	146 000	160 000	6 500	9 600
7030.C	43	146 000	160 000	5 800	8 600
7230.C	50	229 000	253 000	5 200	7 700
AC 71932.C	41	112 000	132 000	6 400	9 500
71932.C	41	112 000	132 000	5 700	8 500
AC 7032.C	46	166 000	184 000	6 100	9 000
7032.C	46	166 000	184 000	5 400	8 000
AC 71934.C	45	115 000	142 000	6 100	9 000
71934.C	45	115 000	142 000	5 400	8 000
AC 7034.C	50	191 000	212 000	5 700	8 400
7034.C	50	191 000	212 000	5 100	7 500
AC 71936.C	47	141 000	175 000	5 700	8 400
71936.C	47	141 000	175 000	5 100	7 500
AC 7036.C	54	214 000	251 000	5 300	7 800
7036.C	54	214 000	251 000	4 700	7 000
AC 71938.C	51	147 000	189 000	5 400	8 100
71938.C	51	147 000	189 000	4 800	7 200
AC 7038.C	55	219 000	265 000	5 000	7 500
7038.C	55	219 000	265 000	4 500	6 700
AC 71940.C	54	179 000	225 000	5 000	7 500
71940.C	54	179 000	225 000	4 500	6 700
AC 7040.C	60	256 000	325 000	4 800	7 100
7040.C	60	256 000	325 000	4 300	6 300
AC 71944.C	56	190 000	251 000	4 700	7 000
71944.C	56	190 000	251 000	4 200	6 200
AC 71948.C	56	196 000	267 000	4 400	6 400
71948.C	60	196 000	267 000	3 900	5 700
71951.C	68	246 000	351 000	3 500	5 200
71956.C	70	255 000	374 000	3 300	4 800

Basic designation	a mm	Basic load ratings		Speed ratings	
		C N	C ₀	n _b Grease min ⁻¹	Oil-air min ⁻¹
AC 71928.E	51	74 900	87 000	6 500	9 500
71928.E	51	74 900	87 000	5 900	8 700
AC 7028.E	58	124 000	138 000	6 200	9 000
7028.E	58	124 000	138 000	5 500	8 000
7228.E	66	201 000	209 000	5 100	7 200
AC 71930.E	56	105 000	124 000	6 000	8 600
71930.E	56	105 000	124 000	5 400	8 000
AC 7030.E	62	138 000	152 000	5 900	8 700
7030.E	62	138 000	152 000	5 200	7 800
7230.E	70	217 000	240 000	4 650	6 900
AC 71932.E	58	105 000	124 000	5 800	8 500
71932.E	58	105 000	124 000	5 100	7 600
AC 7032.E	66	156 000	174 000	5 500	8 100
7032.E	66	156 000	174 000	4 900	7 200
AC 71934.E	61	108 000	133 000	5 400	8 100
71934.E	61	108 000	133 000	4 800	7 100
AC 7034.E	71	181 000	201 000	5 150	7 600
7034.E	71	181 000	201 000	4 600	6 800
AC 71936.E	65	133 000	164 000	5 100	7 600
71936.E	65	133 000	164 000	4 500	6 800
AC 7036.E	77	202 000	238 000	4 800	7 100
7036.E	77	202 000	238 000	4 250	6 300
AC 71938.E	69	139 000	176 000	4 850	7 300
71938.E	69	139 000	176 000	4 300	6 500
AC 7038.E	79	207 000	251 000	4 500	6 750
7038.E	79	207 000	251 000	4 050	6 000
AC 71940.E	75	169 000	211 000	4 500	6 700
71940.E	75	169 000	211 000	4 000	6 000
AC 7040.E	85	242 000	308 000	4 300	6 400
7040.E	85	242 000	308 000	3 850	5 700
AC 71944.E	80	179 000	234 000	4 250	6 200
71944.E	80	179 000	234 000	3 750	5 500
AC 71948.E	84	184 000	249 000	4 100	6 000
71948.E	84	184 000	249 000	3 500	5 100
71952.E	95	232 000	327 000	3 300	4 700
71956.E	100	240 000	349 000	3 100	4 400

Further types with ceramic balls on demand.

4. Equivalent Data of Precision Angular Contact Ball Bearings

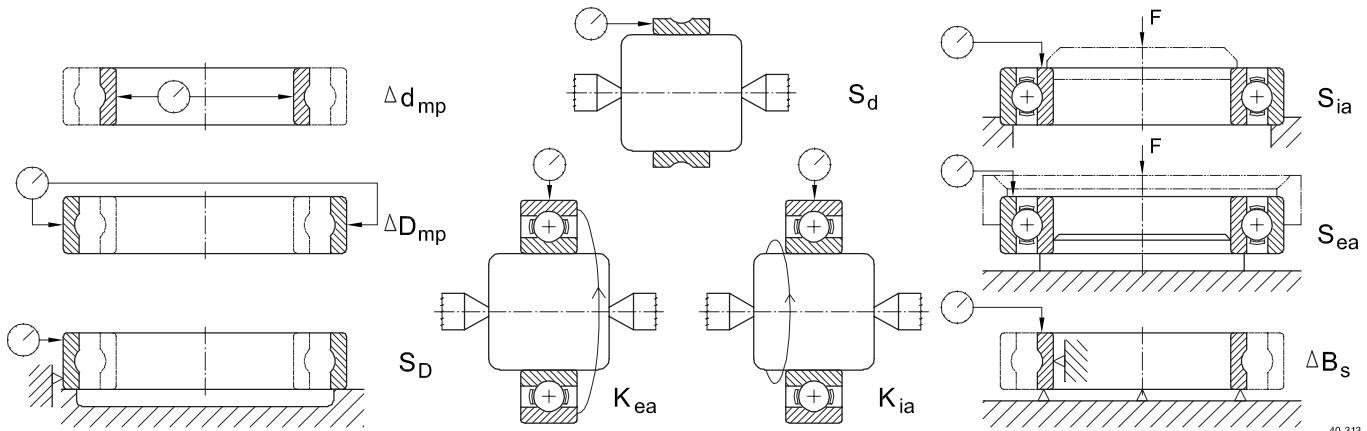

40-313

1. Table of precision classes

Designation IBC	P5	P4	P4A	P2H	P2A
DIN (Deutsches Institut für Normung)	P5	P4	P4S		P2
AFBMA STD 20 (Anti-Friction Bearing Manufacturers Association)	ABEC5	ABEC7			ABEC9
ISO 492 (International Standards Organisation)	Class 5	Class 4			Class 2
BS 292 (British Standards Institution)	EP5	EP7			EP9

2. Tolerances of precision classes

Designation according to ISO	Feature	Inner ring	Outer ring	P4	P4A	P2H	P2A
Δd_{mp}	Max. deviation of the mean bore diameter from the nominal	X		P4	P4	P4	P2
ΔD_{mp}	Max. deviation of mean outside diameter from the nominal		X	P4	P4	P4	P2
K_{ia}	Radial runout of assembled bearing inner ring	X		P4	P2	P2	P2
K_{ea}	Radial runout of assembled bearing outer ring		X	P4	P2	P2	P2
S_d	Side face runout referring to bore of inner ring	X		P4	P2	P2	P2
S_D	Variation in inclination of outside cylindrical surface to outer ring side face		X	P4	P2	P2	P2
S_{ia}	Side face runout of the assembled bearing inner ring	X		P4	P2	P2	P2
S_{ea}	Side face runout referring to raceway of assembled bearing outer ring		X	P4	P2	P2	P2
V_{Bs}/V_{Cs}	Ring width variation	X	X	P4	P4	P2	P2
$\Delta B_s/\Delta C_s$	Deviation of inner ring width	X	X	P4	P4	P4	P2

3. Interchange Data

Manufacturer	IBC	FAG	NSK	SKF	SNFA
Precision Classes	P5	P5	P5	P5	
	P4	P4	P4	P4	7
	P4A	P4S	P3	P4A	
	P2H	(P4S)	(P3)	(P4A)	
	P2A			PA9A	9

5. Designation of IBC Precision Angular Contact Ball Bearings 40°

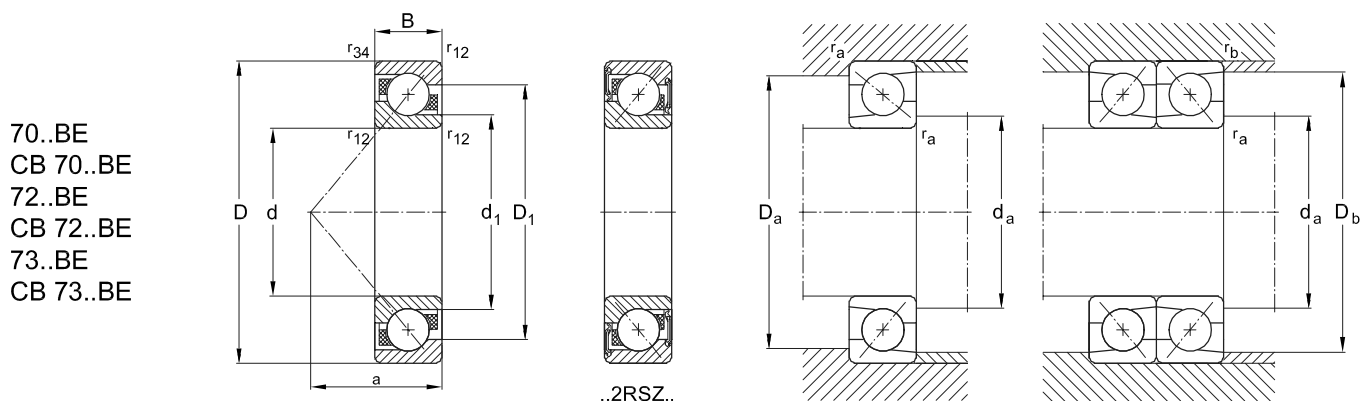

70..BE
CB 70..BE
72..BE
CB 72..BE
73..BE
CB 73..BE

44-604

CB 70 05 .BE P . P6 .DBA
72 06 .BE K . P5 .UL
73 05 .BE P .2RSZ.P5 .UO
72 05 .BE J . UA
73 07 .BE M . P6 .UA
ACC- 73 08 .BE M . P5 .UO .A15.GH62

Material	
-	Steel balls 100 Cr6
CB	Ceramic balls Si ₃ N ₄
AC-	Rings ATCoated
ACC-	Rings ATCoated + balls Si ₃ N ₄

Series	
70..	
72..	
73..	

Bore code	
00	10 mm
02	15 mm
01	12 mm
03	17 mm
At number 04 and upward x 5 [mm]	

Design C	
BE	40° contact angle reinforced inner construction

Cage	
P	Window cage PA 6.6 glass fibre reinforced
M	Solid machined brass
J	Steel sheet
K	Window cage PEEK glass fibre reinforced

Lubrication	
-	Corrosion protected
G..	BearLub grease

Coating with ATCoat	
A11	Inner and outer ring ATCoated
A15	Inner and outer ring ATCoated, rolling elements and cage corrosion resistant*
A 21	Inner ring ATCoated
A 31	Outer ring ATCoated

Axial clearance/preload, universal bearing	
UA	Normal axial clearance
UB	Small axial clearance
UL	Light preload
UO	Without play
A...-	Axial clearance range
Bearing arrangement DB, DF, DT	

Precision classes	
P6	Dimensional and running accuracy acc. to ISO class 6
P5	Dimensional and running accuracy acc. to ISO class 5
P4	Dimensional and running accuracy acc. to ISO class 4

Sealing	
RSZ	Friction reduced sealing at one side
2RSZ	Friction reduced sealing at both sides
ARSZ	At one side – IR lower bord
BRSZ	At one side – IR high bord

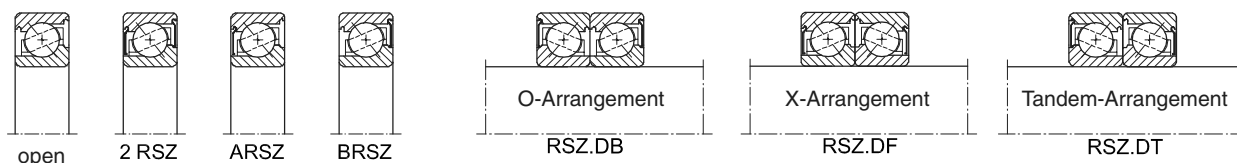

Open sealed 40° Angular Contact Ball Bearings as single and matched bearing sets

*Corrosion protection depending on application, for further information please refer to main catalogue

Designation system 44-900

Detailed information see catalogue TI-1-4044.0/E

IBC Precision Angular Contact Ball Bearings 40°

70..BE
CB 70..BE
72..BE
CB 72..BE
73..BE
CB 73..BE

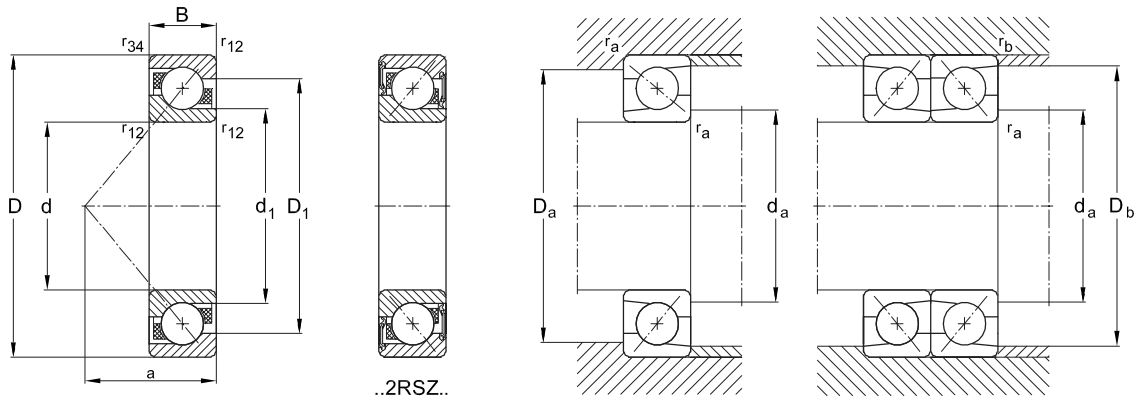

44-804

Primary dimensions			Basic designation	Basic load ratings		Fatigue load limit	Reference speed	Weight
d	D	B		dyn.	stat.			
mm				C	C ₀	P _u (radial)	n _r	kg
				N		N	min ⁻¹	
10	30	9	7200.BE	7 700	3 700	140	30 200	0.030
12	32	10	7201.BE	8 300	4 100	160	28 000	0.036
12	37	12	7301.BE	12 900	6 500	210	25 900	0.060
15	35	11	7202.BE	9 600	5 100	205	25 900	0.045
15	42	13	7302.BE	16 600	9 600	280	21 600	0.083
17	40	12	7203.BE	11 800	6 500	250	21 600	0.065
17	47	14	7303.BE	19 000	10 900	360	19 400	0.110
20	47	14	7204.BE	15 700	8 900	360	18 300	0.110
20	52	15	7304.BE	22 200	13 600	430	16 200	0.140
25	47	12	7005.BE	14 800	9 300	385	18 900	0.074
25	52	15	7205.BE	17 400	10 900	430	16 200	0.130
25	62	17	7305.BE	30 900	19 500	660	14 000	0.230
30	55	13	7006.BE	20 600	13 000	520	15 600	0.110
30	62	16	7206.BE	24 200	15 600	660	12 900	0.200
30	72	19	7306.BE	37 700	25 200	900	11 800	0.340
35	62	14	7007.BE	27 100	17 500	700	14 200	0.150
35	72	17	7207.BE	31 900	21 200	880	11 800	0.280
35	80	21	7307.BE	46 000	31 900	1 150	10 800	0.450
40	68	15	7008.BE	32 100	22 000	880	12 400	0.180
40	80	18	7208.BE	37 800	26 600	1 100	10 200	0.370
40	90	23	7308.BE	57 800	40 500	1 350	9 700	0.630
45	75	16	7009.BE	35 700	24 500	980	11 300	0.230
45	85	19	7209.BE	42 000	29 800	1 250	9 700	0.420
45	100	25	7309.BE	69 600	50 400	1 750	8 600	0.850
50	80	16	7010.BE	37 000	27 500	1 100	10 200	0.250
50	90	20	7210.BE	43 500	33 000	1 350	8 600	0.470
50	110	27	7310.BE	81 500	55 500	2 200	7 500	1.100
55	100	21	7211.BE	55 000	41 500	1 650	8 100	0.620
55	120	29	7311.BE	91 000	71 000	2 550	7 000	1.400
60	110	22	7212.BE	66 000	51 000	2 150	7 300	0.800
60	130	31	7312.BE	104 000	82 500	3 200	6 400	1.750

- Bearings with brass cage M have 5% less capacity due to inner construction.
- Static capacity C₀ of hybride bearings CB = 0.7 C₀ of bearings with steel balls.

IBC Precision Angular Contact Ball Bearings 40°

70..BE
CB 70..BE
72..BE
CB 72..BE
73..BE
CB 73..BE

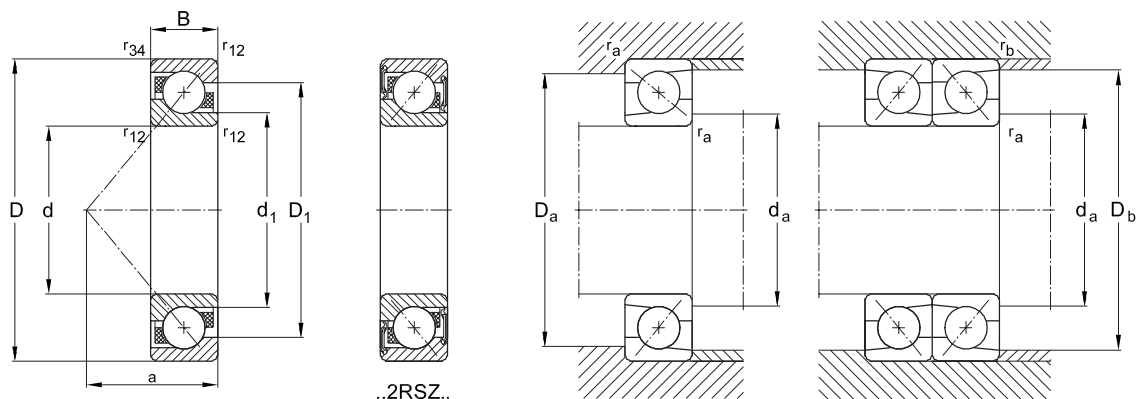

44-604

Basic designation	Dimensions					Abutment and fillet dimensions				
	a	d ₁	D ₁ mm	r ₁₂ _{min}	r ₃₄ _{min}	d _a _{min}	D _a _{max}	D _b _{max} mm	r _a _{max}	r _b _{max}
7200.BE	13	18.2	23.1	0.6	0.3	15.0	25.0	27.0	0.6	0.3
7201.BE	14	20.2	25.1	0.6	0.3	16.2	27.8	29.0	0.6	0.3
7301.BE	16	21.8	28.3	1.0	0.6	17.6	31.4	32.8	1.0	0.6
7202.BE	16	22.2	28.0	0.6	0.3	19.2	30.0	32.0	0.6	0.3
7302.BE	18	26.0	32.6	1.0	0.6	20.6	36.4	37.8	1.0	0.6
7203.BE	18	25.9	31.9	0.6	0.6	21.2	35.0	35.0	0.6	0.3
7303.BE	20	28.7	36.2	1.0	1.0	22.6	41.4	42.0	1.0	0.6
7204.BE	21	30.7	37.2	1.0	0.6	26.0	41.0	42.4	1.0	0.6
7304.BE	23	32.9	41.0	1.1	1.0	27.0	45.0	47.8	1.0	0.6
7005.BE	21.5	31.4	40.4	0.6	0.3	30.0	42.0	45.0	0.6	0.3
7205.BE	24	35.7	42.2	1.0	0.6	31.0	46.0	48.2	1.0	0.6
7305.BE	27	39.4	48.9	1.1	1.0	32.0	55.0	57.8	1.0	0.6
7006.BE	25	37.2	46.9	0.6	0.3	36.0	49.0	53.0	0.6	0.3
7206.BE	27	42.3	50.8	1.1	0.6	36.0	56.0	57.4	1.0	0.6
7306.BE	31	46.2	57.3	1.1	1.0	37.0	65.0	67.8	1.0	0.6
7007.BE	29	43.4	53.3	0.6	0.3	41.0	56.0	60.0	0.6	0.3
7207.BE	31	49.3	59.0	1.1	0.6	42.0	65.0	67.8	1.0	0.6
7307.BE	35	52.4	64.2	1.5	1.0	44.0	71.0	74.4	1.5	1.0
7008.BE	32	49.2	58.8	0.6	0.3	46.0	62.0	66.0	0.6	0.3
7208.BE	34	55.9	66.3	1.1	0.6	47.0	73.0	75.8	1.0	0.6
7308.BE	39	59.4	72.4	1.5	1.0	49.0	81.0	84.4	1.5	1.0
7009.BE	35	53.2	65.3	0.6	0.3	51.0	69.0	73.0	0.6	0.3
7209.BE	37	60.5	70.9	1.1	0.6	52.0	78.0	80.8	1.0	0.6
7309.BE	43	66.3	80.7	1.5	1.0	54.0	91.0	94.4	1.5	1.0
7010.BE	38	57.6	70.3	1.0	0.6	56.0	74.0	78.0	0.6	0.3
7210.BE	39	65.5	75.9	1.5	1.0	57.0	83.0	85.8	1.0	0.6
7310.BE	47	73.5	89.7	2.0	1.0	60.0	100.0	104.0	1.5	1.0
7211.BE	43	72.4	84.1	1.5	1.0	64.0	91.0	94.0	1.5	1.0
7311.BE	51	80.0	97.6	2.0	1.0	65.0	110.0	114.0	2.0	1.0
7212.BE	47	79.3	92.5	1.5	1.0	69.0	101.0	104.0	1.5	1.0
7312.BE	55	87.0	106.0	2.1	1.1	72.0	118.0	123.0	2.0	1.0

IBC Precision Angular Contact Ball Bearings 40°

70..BE
CB 70..BE
72..BE
CB 72..BE
73..BE
CB 73..BE

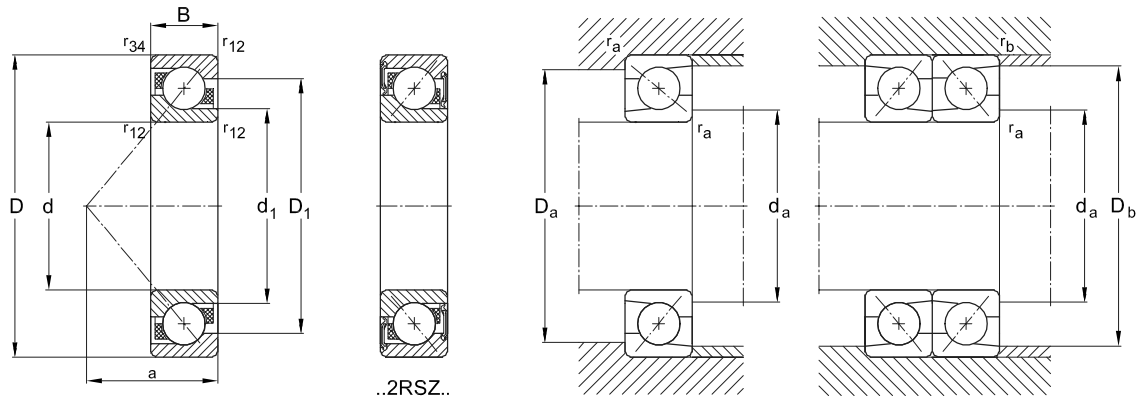

44-604

Primary dimensions		Basic designation	Basic load ratings		Fatigue load limit	Reference speed	Weight
d	D		dyn.	stat.			
mm	B	C	C ₀	P _u (radial) N	n _r min ⁻¹	kg	
65	120	23	74 000	60 500	2 300	6 400	1.000
65	140	33	121 000	89 500	3 650	5 900	2.150
70	125	24	80 000	67 500	2 550	5 900	1.100
70	150	35	133 500	101 000	3 900	5 400	2.650
75	130	25	82 000	72 000	2 650	5 900	1.200
75	160	37	149 000	119 000	4 150	5 400	3.200
80	140	26	92 000	80 000	2 800	5 600	1.400
80	170	39	161 000	131 000	4 500	4 800	3.700
85	150	28	103 500	92 000	3 300	5 100	1.800
85	180	41	172 500	146 000	4 900	4 800	4.300
90	160	30	122 000	107 000	3 700	4 800	2.200
90	190	43	184 000	161 000	5 300	4 300	5.000
95	170	32	133 500	115 000	4 400	4 600	2.600
100	180	34	148 500	131 000	4 400	4 300	3.200
100	215	47	222 000	207 000	7 000	3 700	7.200
105	190	36	164 500	148 000	4 800	4 100	4.200
110	200	38	176 000	164 500	4 900	3 700	4.500
110	240	50	257 500	257 500	7 200	3 400	9.300
120	215	40	191 000	184 000	5 300	3 400	5.300
120	260	55	287 500	299 000	7 700	2 700	12.400
130	230	40	214 000	218 500	6 100	3 200	6.200
130	280	58	316 000	345 000	9 000	2 700	15.200
140	250	42	225 500	244 000	6 500	2 700	8.600
140	300	62	345 000	391 000	10 000	2 400	20.500
150	270	45	257 500	293 000	7 000	2 400	11.000
150	320	65	373 500	448 500	10 500	2 200	25.000
160	290	48	292 000	322 000	8 500	2 300	13.500
170	310	52	334 000	354 000	9 300	2 100	16.000

- Bearings with brass cage M have 5% less capacity due to inner construction.
- Static capacity C₀ of hybride bearings CB = 0.7 C₀ of bearings with steel balls.

IBC Precision Angular Contact Ball Bearings 40°

70..BE
CB 70..BE
72..BE
CB 72..BE
73..BE
CB 73..BE

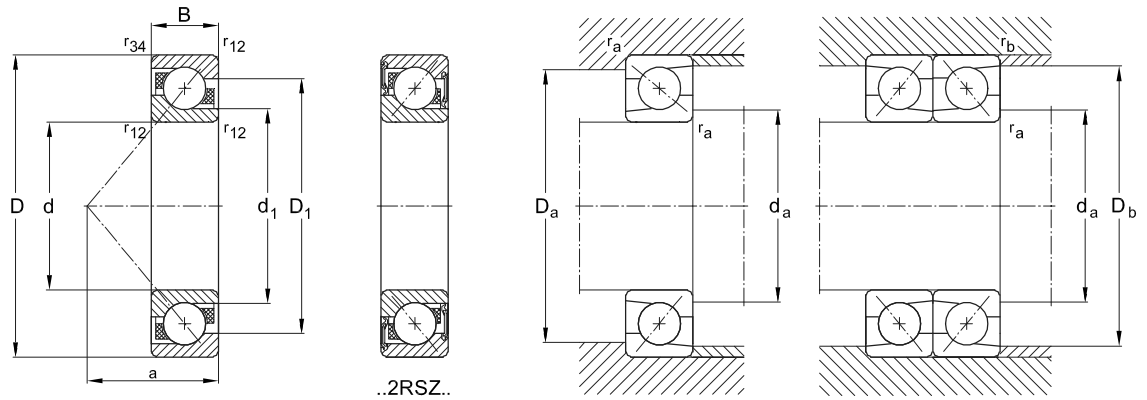

44-604

Basic designation	Dimensions					Abutment and fillet dimensions				
	a	d ₁	D ₁ mm	r ₁₂ _{min}	r ₃₄ _{min}	d _a _{min}	D _a _{max}	D _b _{max} mm	r _a _{max}	r _b _{max}
7213.BE	50	86.3	101.0	1.5	1.0	74.0	111.0	114.0	1.5	1.0
7313.BE	60	93.8	114.0	2.1	1.1	77.0	128.0	133.0	2.0	1.0
7214.BE	53	91.3	106.0	1.5	1.0	79.0	116.0	119.0	1.5	1.0
7314.BE	64	100.0	123.0	2.1	1.1	82.0	138.0	143.0	2.0	1.0
7215.BE	56	96.5	111.0	1.5	1.0	84.0	121.0	124.0	1.5	1.0
7315.BE	68	108.0	130.0	2.1	1.1	87.0	148.0	153.0	2.0	1.0
7216.BE	59	104.0	118.0	2.0	1.0	91.0	129.0	134.0	2.0	1.0
7316.BE	72	115.0	137.0	2.1	1.1	92.0	158.0	163.0	2.0	1.0
7217.BE	63	110.0	127.0	2.0	1.0	96.0	139.0	144.0	2.0	1.0
7317.BE	76	122.0	145.0	3.0	1.1	99.0	166.0	173.0	2.5	1.0
7218.BE	67	117.0	135.0	2.0	1.0	101.0	149.0	154.0	2.0	1.0
7318.BE	80	129.0	153.0	3.0	1.1	104.0	176.0	183.0	2.5	1.0
7219.BE	72	124.0	143.0	2.1	1.1	107.0	158.0	163.0	2.0	1.0
7220.BE	76	131.0	151.0	2.1	1.1	112.0	168.0	173.0	2.0	1.0
7320.BE	90	145.0	173.0	3.0	1.1	114.0	201.0	208.0	2.5	1.0
7221.BE	80	138.0	159.0	2.1	1.1	117.0	178.0	183.0	2.0	1.0
7222.BE	84	145.0	167.0	2.1	1.1	122.0	188.0	193.0	2.0	1.0
7322.BE	98	161.0	194.0	3.0	1.1	124.0	226.0	233.0	2.5	1.0
7224.BE	90	157.0	179.0	2.1	1.1	132.0	203.0	208.0	2.0	1.0
7324.BE	107	178.0	211.0	3.0	1.1	134.0	246.0	253.0	2.5	1.0
7226.BE	96	169.0	193.0	3.0	1.1	144.0	216.0	222.0	2.5	1.0
7326.BE	115	190.0	228.0	4.0	1.5	147.0	263.0	271.0	3.0	1.5
7228.BE	103	183.0	210.0	3.0	1.1	154.0	236.0	243.0	2.5	1.0
7328.BE	123	203.0	243.0	4.0	1.5	157.0	283.0	291.0	3.0	1.5
7230.BE	111	197.0	226.0	3.0	1.1	164.0	256.0	263.0	2.5	1.0
7330.BE	131	216.0	259.0	4.0	1.5	167.0	303.0	311.0	3.0	1.5
7232.BE	118	211.0	242.0	3.0	1.1	174.0	276.0	283.0	2.5	1.0
7234.BE	126	226.0	260.0	3.0	1.1	185.0	297.0	304.0	2.5	1.0

6. Designation of IBC Precision Single Row Deep Groove Ball Bearings

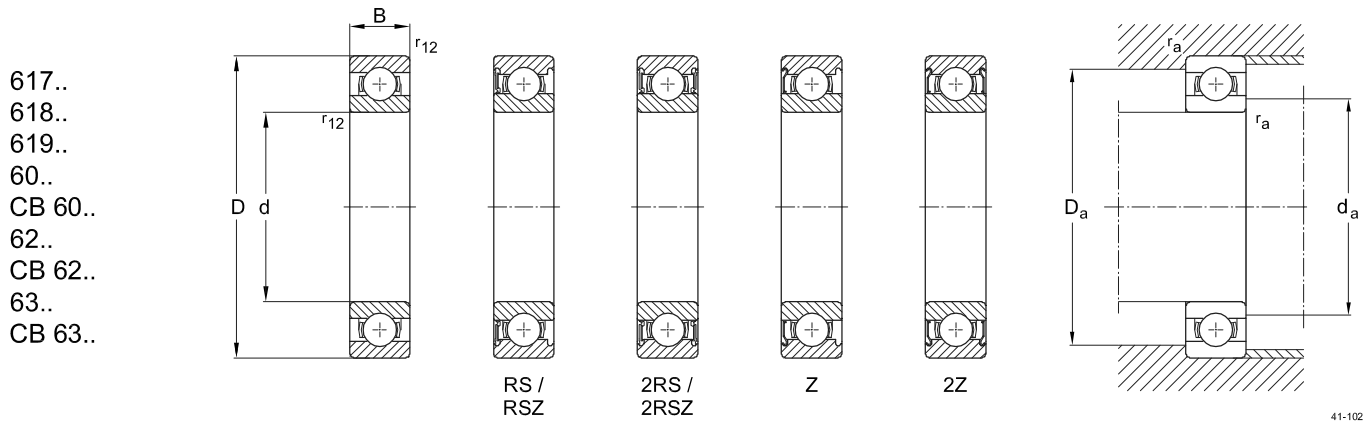

CB 60 14 .TB .P63 .GH73
617 01 .2RS .Y
618 05 .2Z .C3
63 08 .2Z .P64
ACC- 60 10 .TB .P53 .X22 .A15 .GH62

Material	
-	Steel rollers 100 Cr6
CB	Ceramic rollers Si ₃ N ₄
AC-	Rings ATCoated
ACC-	Rings ATCoated + balls Si ₃ N ₄

Series	
617..	60..
618..	62..
619..	63..

Bore code	
00	10 mm
01	12 mm
02	15 mm
03	17 mm
At number 04 and upward x 5 [mm]	

Sealing	
-	Open
Z	Shield (at one side)
2Z	Shield (at both sides)
RS	Seal (at one side)
2RS	Seal (at both sides)
RSZ	Seal, low friction, at one side up to Ø 62 mm
2RSZ	Seal, low friction, at both sides up to Ø 62 mm
RSD	Seal, low friction, at one side at Ø 62 mm and above
2RSD	Seal, low friction, at both sides at Ø 62 mm and above

Cage			
-	Steel sheet cage (standard)	JH	Steel sheet snap cage
TB	Fabric reinforced phenolic resin cage located on inner ring	THB	Fabric reinforced phenolic resin cage
TA	Fabric reinforced phenolic resin cage located on outer ring	MA	Solid machined brass, located on outer ring
LB	Aluminium cage located on inner ring	MB	Solid machined brass, located on inner ring
LA	Aluminium cage located on outer ring	KA	PEEK located on outer ring
PH	Polyamide snap cage	KB	PEEK located on inner ring
		Y	Brass sheet cage

Lubrication	
-	Corrosion protected
G..	BearLub grease

Coating with ATCoat	
A11	Inner and outer ring ATCoated
A15	Inner and outer ring ATCoated, rolling elements and cage corrosion resistant*
A 21	Inner ring ATCoated
A 31	Outer ring ATCoated

Grading	
X03	Outer diameter in 3 groups
X20	Bore in 2 groups
X22	Outer diameter and bore in 2 groups
X33	Outer diameter and bore in 3 groups

Precision classes and radial clearance	
P6, P63, P5, P52, P53	
C2	
CN	
C3	
C4	
e.g.: P53 = P5 + C3	

Designation system 41-900

*Corrosion protection depending on application, for further information please refer to main catalogue

6.1 IBC Single Row Deep Groove Ball Bearings

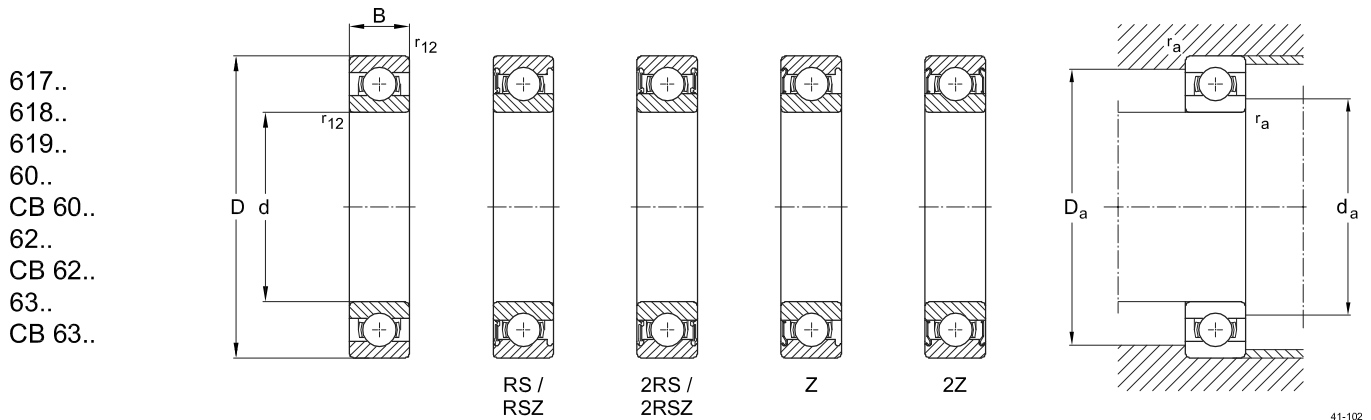

41-102

Primary dimensions			Basic designation	Dimensions			Basic load ratings		Speed ratings		Weight kg
d	D mm	B		da	Da mm	r ₁₂	C N	C ₀	n _{B_{Grease}} min ⁻¹	n _{B_{Oil}}	
10	15	3	61700	11.0	14.0	0.1	870	440	36 000	43 000	0.002
10	19	5	61800	12.0	17.0	0.3	1 750	850	37 000	43 000	0.005
10	22	6	61900	12.0	20.0	0.3	1 950	750	34 000	41 000	0.010
10	26	8	6000	12.0	24.0	0.3	4 600	2 000	31 000	36 500	0.020
10	30	9	6200	14.0	26.0	0.6	5 100	2 400	26 000	32 000	0.032
10	35	11	6300	14.0	31.0	0.6	8 100	3 500	21 000	27 000	0.055
12	18	4	61701	13.5	17.0	0.2	940	540	31 000	37 000	0.005
12	21	5	61801	14.0	19.0	0.3	1 800	950	33 000	39 000	0.006
12	24	6	61901	14.0	22.0	0.3	2 900	1 450	31 000	36 000	0.011
12	28	8	6001	14.0	26.0	0.3	5 100	2 400	26 500	33 000	0.022
12	32	10	6201	16.0	28.0	0.6	6 900	3 100	23 000	29 000	0.037
12	37	12	6301	17.0	32.0	1.0	9 700	4 200	19 000	25 000	0.060
15	21	4	61702	16.5	20.0	0.2	960	590	27 000	32 000	0.006
15	24	5	61802	17.0	22.0	0.3	2 000	1 250	28 000	33 000	0.007
15	28	7	61902	17.0	26.0	0.3	4 100	2 100	26 000	30 000	0.017
15	32	9	6002	17.0	30.0	0.3	5 600	2 900	22 500	30 000	0.030
15	35	11	6202	19.0	31.0	0.6	7 800	3 800	20 000	24 000	0.045
15	42	13	6302	20.0	37.0	1.0	11 400	5 400	17 500	21 000	0.080
17	23	4	61703	18.5	21.5	0.2	1 020	670	25 000	30 000	0.006
17	26	5	61803	19.0	24.0	0.3	2 200	1 400	26 000	32 000	0.009
17	30	7	61903	19.0	28.0	0.3	4 350	2 350	24 000	28 000	0.018
17	35	10	6003	19.0	33.0	0.3	6 100	3 300	20 000	26 000	0.042
17	40	12	6203	21.0	36.0	0.6	9 600	4 800	18 000	21 000	0.070
17	47	14	6303	22.0	42.0	1.0	13 500	6 600	17 000	20 000	0.120
20	27	4	61704	22.0	25.5	0.2	1 060	740	21 000	25 000	0.008
20	32	7	61804	22.0	30.0	0.3	3 450	2 250	20 000	26 000	0.020
20	37	9	61904	22.0	35.0	0.3	6 550	3 650	19 000	23 000	0.040
20	42	12	6004	24.0	38.0	0.6	9 500	5 200	17 500	21 000	0.070
20	47	14	6204	25.0	42.0	1.0	12 800	6 700	15 000	19 000	0.110
20	52	15	6304	26.5	45.5	1.1	15 900	7 800	14 000	17 000	0.140
25	32	4	61705	27.0	30.5	0.2	1 110	860	19 000	23 000	0.010
25	37	7	61805	27.0	35.0	0.3	4 360	2 600	18 000	25 000	0.022
25	42	9	61905	27.0	40.0	0.3	6 650	4 100	16 000	19 000	0.041
25	47	12	6005	29.0	43.0	0.6	11 500	6 800	15 500	19 000	0.080
25	52	15	6205	30.0	47.0	1.0	14 000	7 900	13 000	16 000	0.130
25	62	17	6305	31.5	55.5	1.1	22 500	11 600	12 000	14 000	0.250

IBC Single Row Deep Groove Ball Bearings

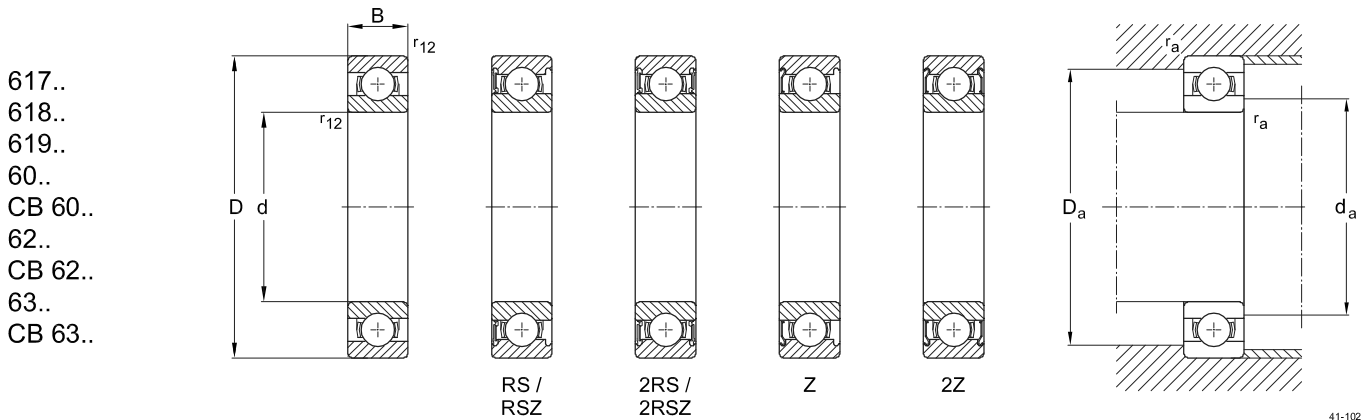

41-102

Primary dimensions			Basic designation	Dimensions			Basic load ratings		Speed ratings		Weight kg
d	D mm	B		da	Da mm	r ₁₂	C N	C ₀	n _{bGrease} min ⁻¹	n _{bOil}	
30	42	7	61806	32.0	40.0	0.3	4 500	2 900	15 000	18 000	0.027
30	47	9	61906	32.0	45.0	0.3	7 800	4 700	14 000	17 000	0.045
30	55	13	6006	35.0	50.0	1.0	13 500	8 300	13 000	16 000	0.130
30	62	16	6206	35.0	57.0	1.0	19 500	11 300	11 000	13 000	0.190
30	72	19	6306	36.5	65.5	1.1	28 100	16 000	9 500	12 000	0.350
35	47	7	61807	37.0	45.0	0.3	4 800	3 300	13 000	16 000	0.031
35	55	10	61907	39.0	51.0	0.6	9 600	6 200	12 000	14 000	0.073
35	62	14	6007	40.0	57.0	1.0	16 000	10 300	11 000	13 500	0.160
35	72	17	6207	41.5	65.5	1.0	25 500	15 300	9 500	11 500	0.300
35	80	21	6307	43.0	72.0	1.5	33 500	18 500	8 500	10 000	0.460
40	52	7	61808	42.0	50.0	0.3	4 900	4 000	11 000	14 000	0.034
40	62	12	61908	44.0	58.0	0.6	14 500	10 200	11 000	13 000	0.110
40	68	15	6008	45.0	63.0	1.0	17 000	11 700	10 000	12 500	0.190
40	80	18	6208	46.5	73.5	1.0	30 700	19 000	9 000	11 000	0.360
40	90	23	6308	48.0	82.0	1.5	41 000	24 000	7 500	9 000	0.630
45	58	7	61809	47.0	56.0	0.3	6 400	5 600	9 500	12 000	0.040
45	68	12	61909	49.0	64.0	0.6	14 000	9 800	9 700	11 000	0.120
45	75	16	6009	50.0	70.0	1.0	21 000	15 000	9 400	11 000	0.250
45	85	19	6209	51.5	78.5	1.0	33 200	21 600	7 500	9 500	0.410
45	100	25	6309	53.0	92.0	1.5	52 700	31 500	6 800	8 200	0.850
50	65	7	61810	52.0	63.0	0.3	6 800	6 300	9 000	12 000	0.057
50	72	12	61910	54.0	68.0	0.6	14 600	10 400	9 000	10 500	0.130
50	80	16	6010	55.0	75.0	1.0	21 800	16 300	8 600	10 500	0.280
50	90	20	6210	56.5	83.5	1.1	35 100	23 200	7 000	8 500	0.450
50	110	27	6310	59.0	101.0	2.0	61 800	38 000	6 400	7 700	1.050
55	72	9	61811	57.0	70.0	0.3	9 000	8 500	8 500	10 000	0.083
55	80	13	61911	60.0	75.0	1.0	15 900	11 400	8 000	9 500	0.190
55	90	18	6011	61.5	83.5	1.1	28 300	21 300	7 800	9 300	0.380
55	100	21	6211	63.0	92.0	1.5	43 600	29 000	6 300	7 600	0.610
55	120	29	6311	64.0	111.0	2.0	71 500	45 000	5 300	6 300	1.350
60	78	10	61812	62.0	76.0	0.3	8 700	6 700	8 000	9 500	0.120
60	85	13	61912	65.0	80.0	1.0	16 500	12 000	7 500	9 000	0.200
60	95	18	6012	66.5	88.5	1.1	30 000	23 500	6 800	8 100	0.420
60	110	22	6212	68.0	102.0	1.5	52 400	36 000	6 100	7 000	0.780
60	130	31	6312	71.0	119.0	2.1	81 900	52 000	5 000	6 000	1.700

IBC Single Row Deep Groove Ball Bearings

617..
618..
619..
60..
CB 60..
62..
CB 62..
63..
CB 63..

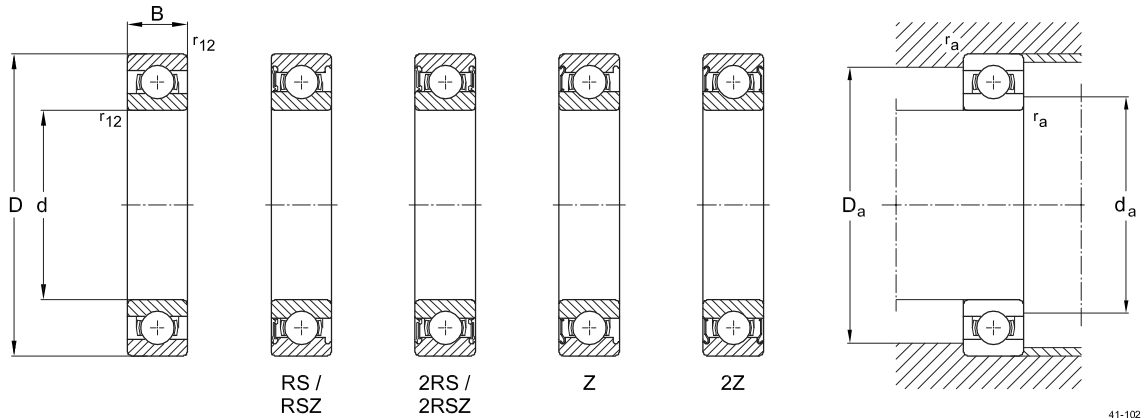

41-102

Primary dimensions			Basic designation	Dimensions			Basic load ratings		Speed ratings		Weight kg
d	D mm	B		da	Da mm	r ₁₂	C N	C ₀	n _{BGrease} min ⁻¹	n _{BOil}	
65	85	10	61813	69.0	81.0	0.6	12 200	12 000	7 000	8 500	0.130
65	90	13	61913	70.0	85.0	1.0	17 400	13 400	6 700	8 000	0.220
65	100	18	6013	71.5	93.5	1.1	31 000	25 500	6 400	7 500	0.440
65	120	23	6213	73.0	112.0	1.5	55 900	40 500	5 500	6 500	0.990
65	140	33	6312	76.0	129.0	2.1	92 300	60 000	4 800	5 600	2.100
70	90	10	61814	74.0	86.0	0.6	12 500	10 000	6 700	8 000	0.160
70	100	16	61914	75.0	95.0	1.0	24 000	18 300	6 300	7 500	0.350
70	110	20	6014	76.5	103.5	1.1	38 500	31 600	6 100	7 200	0.600
70	125	24	6214	78.0	117.0	1.5	67 400	49 300	5 000	6 000	1.100
70	150	35	6314	81.0	139.0	2.1	104 000	69 000	4 500	5 400	2.400
75	95	10	61815	79.0	91.0	0.6	12 800	12 100	6 300	7 500	0.160
75	105	16	61915	80.0	100.0	1.0	24 200	19 300	6 000	7 000	0.370
75	115	20	6015	81.5	108.5	1.1	40 000	33 800	5 700	6 800	0.640
75	130	25	6215	83.0	122.0	1.5	66 300	49 000	4 800	5 600	1.200
75	160	37	6315	86.0	149.0	2.1	114 000	76 500	4 400	5 100	3.000
80	100	10	61816	84.0	96.0	0.6	12 900	13 700	6 000	7 000	0.170
80	110	16	61916	85.0	105.0	1.0	25 100	20 500	5 600	6 700	0.380
80	125	22	6016	86.5	118.5	1.1	47 500	40 000	5 300	6 400	0.850
80	140	26	6216	89.0	131.0	2.0	72 700	53 000	4 600	5 400	1.400
80	170	39	6316	91.0	159.0	2.1	124 000	87 000	3 900	4 600	3.600
85	110	13	61817	90.0	105.0	1.0	19 300	20 000	5 300	6 300	0.290
85	120	18	61917	91.5	113.5	1.1	32 000	30 000	5 300	6 300	0.550
85	130	22	6017	91.5	123.5	1.1	50 000	43 500	5 100	6 000	0.890
90	115	13	61818	95.0	110.0	1.0	19 600	20 400	5 300	6 300	0.300
90	125	18	61918	96.5	118.5	1.1	33 200	31 500	5 000	6 000	0.590
90	140	24	6018	98.0	132.0	1.5	59 000	51 000	4 800	5 700	1.150
95	120	16	61819	100.0	115.0	1.0	19 900	17 600	5 000	6 000	0.310
95	130	18	61919	101.5	123.5	1.1	35 000	34 000	4 800	5 600	0.610
95	145	24	6019	103.0	137.0	1.5	60 600	54 200	4 500	5 400	1.200
100	125	13	61820	105.0	120.0	1.0	19 900	21 200	4 800	5 600	0.310
100	140	20	61920	106.5	133.5	1.1	43 000	42 000	4 500	5 300	0.830
100	150	24	6020	108.0	142.0	1.5	61 000	54 000	4 300	5 100	1.300
105	130	13	61821	110.0	125.0	1.0	20 800	19 600	4 500	5 300	0.350
105	145	20	61921	111.5	138.5	1.1	45 000	44 000	4 300	5 000	0.880
105	160	26	6021	114.0	151.0	2.0	73 000	69 000	4 000	4 800	1.600

IBC Single Row Deep Groove Ball Bearings

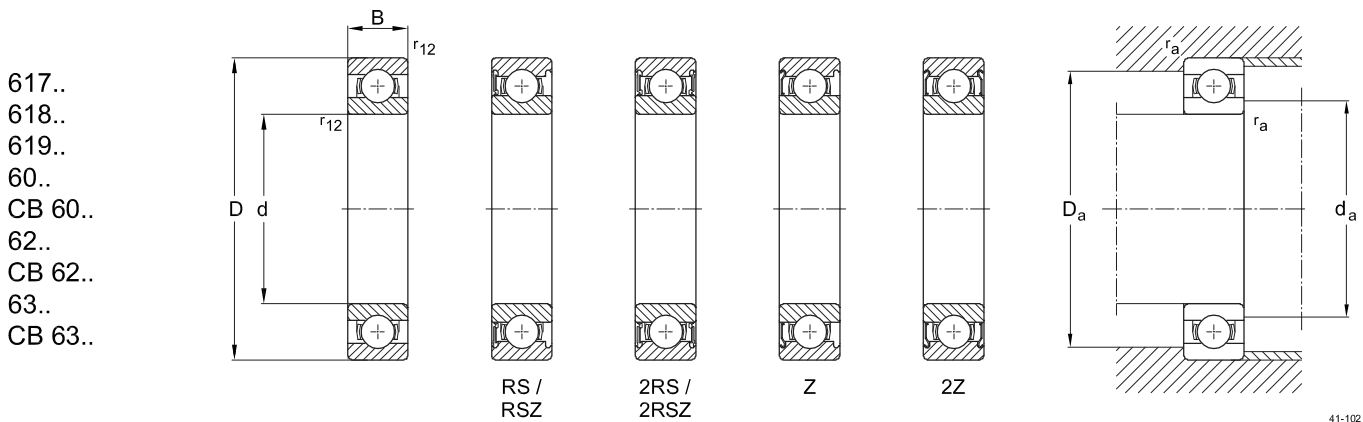

Primary dimensions			Basic designation	Dimensions			Basic load ratings		Speed ratings		Weight kg
d	D mm	B		da	Da mm	r ₁₂	C N	C ₀	n _{bGrease} min ⁻¹	n _{bOil}	
110	140	16	61822	115.0	135.0	1.0	28 100	29 000	4 300	5 000	0.600
110	150	20	61922	116.5	143.5	1.1	44 000	45 000	4 000	4 800	0.900
110	170	28	6022	119.0	161.0	2.0	82 000	73 600	3 800	4 600	1.950
120	150	16	61824	125.0	145.0	1.0	29 100	32 500	3 800	4 500	0.650
120	165	22	61924	126.5	159.0	1.1	56 000	57 000	3 600	2 040	1.200
120	180	28	6024	129.0	171.0	2.0	85 300	80 500	3 600	4 200	2.050
130	165	18	61826	136.5	158.5	1.1	38 000	43 000	3 600	4 300	0.930
130	180	24	61926	138.0	172.0	1.5	65 000	67 000	3 400	4 000	1.600
130	200	33	6026	139.0	191.0	2.0	108 000	100 000	3 300	3 900	3.150
140	175	18	61828	146.5	168.5	1.1	39 000	46 500	3 400	4 000	1.000
140	190	24	61928	148.0	182.0	1.5	67 000	73 000	3 200	3 800	1.900
140	210	33	6028	149.0	201.0	2.0	112 000	101 000	3 100	3 600	3.350
150	190	20	61830	156.5	183.5	1.1	48 800	61 000	3 000	3 600	1.040
150	210	28	61930	159.0	201.0	2.0	88 500	93 000	2 800	3 400	3.050
150	225	35	6030	161.0	214.0	2.1	127 000	126 000	2 600	3 300	4.800
160	200	20	61832	167.0	193.0	1.0	49 500	65 000	2 900	3 500	1.460
160	220	28	61932	169.0	211.0	2.0	92 500	99 000	2 600	3 300	3.300
160	240	38	6032	171.0	229.0	2.1	145 000	145 000	2 400	3 000	5.900
170	215	22	61834	177.0	208.0	1.0	62 000	79 800	2 600	3 200	1.900
170	230	28	61934	179.0	220.0	2.0	94 000	107 000	2 400	3 000	3.500
170	260	42	6034	181.0	249.0	2.1	170 000	175 000	2 200	2 800	7.900
180	225	22	61836	187.0	218.0	1.0	62 500	82 000	2 400	3 000	2.000
180	250	33	61936	189.0	241.0	2.0	120 000	136 000	2 200	2 800	5.100
180	280	46	6036	191.0	269.0	2.1	200 000	205 000	2 100	2 700	10.400
190	240	24	61838	199.0	231.0	1.5	76 000	97 000	2 200	2 800	2.700
190	260	33	61938	200.0	250.0	2.0	118 000	135 000	2 100	2 700	5.300
190	290	46	6038	201.0	279.0	2.1	208 000	220 000	2 000	2 600	11.000
200	250	24	61840	209.0	242.0	1.5	77 000	104 000	2 100	2 700	2.800
200	280	38	61940	212.0	268.0	2.0	150 000	170 000	2 000	2 600	7.400
200	310	51	6040	211.0	299.0	2.1	220 000	248 000	1 900	2 400	14.400
220	270	28	61844	220.0	313.0	1.5	79 000	111 000	2 000	2 500	3.000
220	300	38	61944	231.0	288.0	2.0	152 000	180 000	1 900	2 400	8.000
220	340	56	6044	233.0	327.0	3.0	249 000	297 000	1 800	2 200	18.500

IBC Single Row Deep Groove Ball Bearings

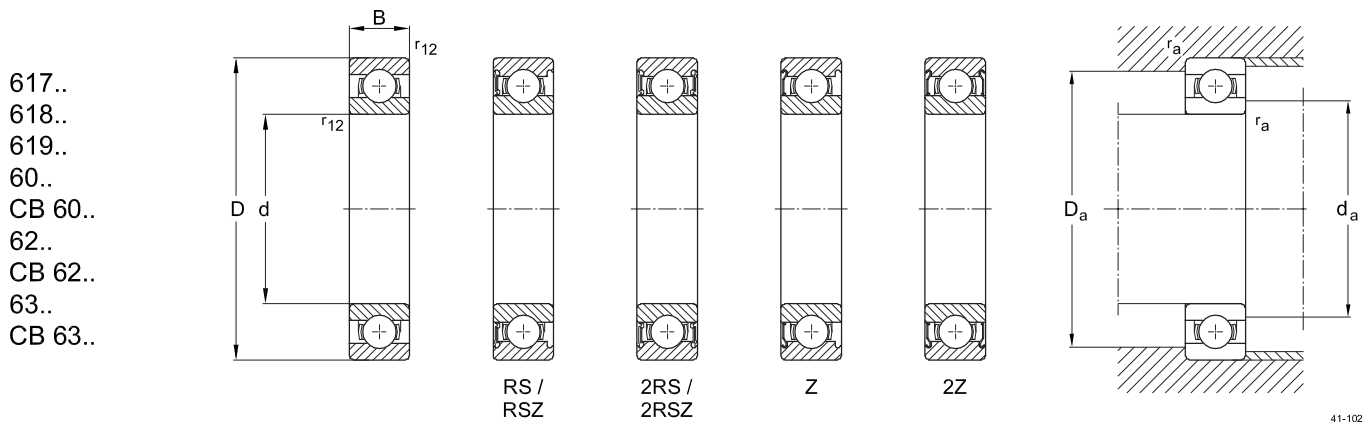

41-102

Primary dimensions			Basic designation	Dimensions			Basic load ratings		Speed ratings		Weight kg
d	D mm	B		da	Da mm	r ₁₂	C N	C ₀	n _{BGrease} min ⁻¹	n _{BOil}	
240	300	28	61848	250.0	292.0	2.0	110 000	150 000	1 900	2 300	4.500
240	320	38	61948	252.0	308.0	2.0	160 000	200 000	1 800	2 200	8.500
240	360	56	6048	253.0	347.0	3.0	261 000	319 000	1 700	2 000	20.000
260	320	28	61852	270.0	310.0	2.0	112 000	164 000	1 700	2 000	4.800
260	360	46	61952	272.0	348.0	2.0	215 000	272 000	1 600	1 900	14.500
260	400	65	6052	276.0	384.0	4.0	295 000	378 000	1 600	1 800	29.500
280	350	33	61856	289.0	341.0	2.0	140 000	200 000	1 600	1 900	7.400
280	380	46	61956	292.0	368.0	2.0	220 000	290 000	1 500	1 800	15.000
280	420	65	6056	296.0	404.0	4.0	305 000	410 000	1 400	1 700	31.000
300	380	38	61860	312.0	368.0	2.0	175 000	245 000	1 400	1 700	10.500
300	420	56	61960	314.0	406.0	2.5	270 000	380 000	1 300	1 600	24.500
300	460	74	6060	317.0	444.0	3.0	360 000	500 000	1 200	1 500	44.000
320	400	38	61864	332.0	388.0	2.0	173 000	258 000	1 300	1 600	11.000
320	440	56	61964	333.0	426.0	2.5	278 000	400 000	1 200	1 500	26.000
320	480	74	6064	337.0	464.0	3.0	372 000	540 000	1 100	1 400	46.000
340	420	38	61868	352.0	408.0	2.0	178 000	275 000	1 200	1 500	11.500
340	460	56	61968	354.0	446.0	2.5	282 000	425 000	1 100	1 400	27.000
360	440	38	61872	371.0	429.0	2.0	182 000	286 000	1 200	1 500	12.000
360	480	56	61972	373.0	466.0	2.5	292 000	450 000	1 100	1 400	28.000
380	480	48	61876	392.0	489.0	2.0	242 000	390 000	1 100	1 400	20.000
380	520	65	61976	396.0	503.0	3.0	340 000	540 000	1 000	1 300	40.000
400	500	46	61880	412.0	488.0	2.0	250 000	410 000	1 100	1 300	15.500
400	540	65	61980	416.0	524.0	3.0	350 000	570 000	1 000	1 200	41.500
420	520	46	61884	431.0	509.0	2.0	252 000	425 000	975	1 200	22.000
420	560	65	61984	436.0	544.0	3.0	352 000	600 000	950	1 100	43.000
440	540	46	61888	451.0	529.0	2.0	255 000	440 000	950	1 100	22.000
440	600	74	61988	457.0	583.0	3.0	410 000	720 000	900	1 100	61.000
460	580	56	61892	473.0	567.0	2.5	320 000	570 000	925	1 100	35.000
460	620	74	61992	477.0	603.0	3.0	425 000	750 000	875	1 000	62.500
480	600	58	61896	494.0	586.0	2.5	325 000	600 000	875	1 000	37.000
480	650	78	61996	500.0	630.0	4.0	450 000	815 000	850	975	74.000
500	620	56	618/500	514.0	606.0	2.5	335 000	620 000	825	975	37.500
500	670	78	619/500	520.0	650.0	4.0	465 000	870 000	800	925	77.000

7. Designation of IBC Precision Cylindrical Roller Bearings

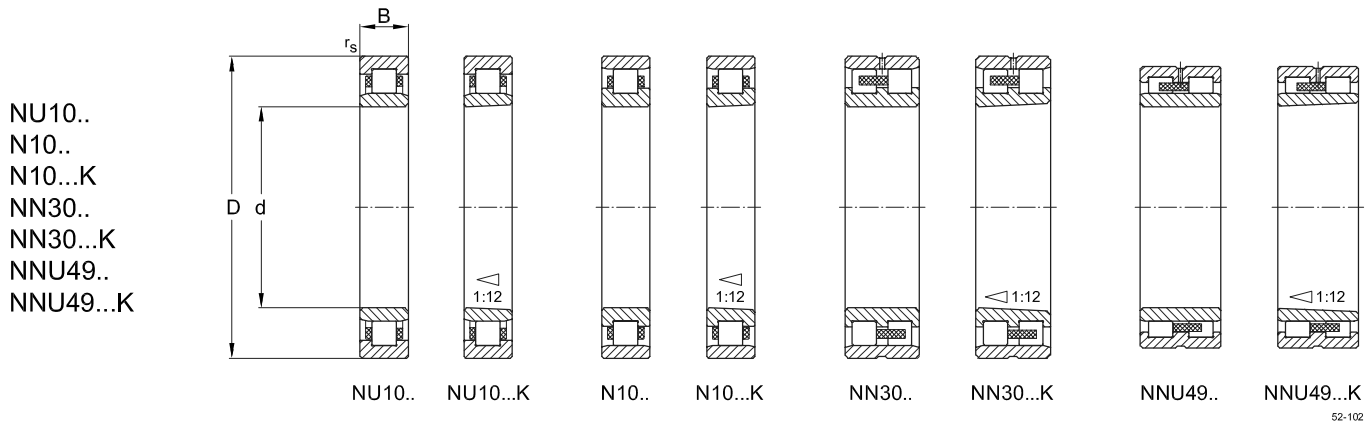

NU	10	08	.	M	.P52	.A26
AC-	N	10	20	.	M	.SP .A11
CR	N	10	15	K	.	M .SP
NNU	49	24	K	.	W33 .M .SPC2X	.A26
NN	30	18	K	.	W33 .M .SP	

Material	
-	Steel rollers 100 Cr6
CR	Ceramic rollers Si ₃ N ₄
AC-	Rings ATCoated
ACC-	Rings ATCoated + rollers Si ₃ N ₄

Design	
N..	
NN..	
NU..	
NNU..	

Series	
10..	
30..	
49..	

Bore code	
00	10 mm
01	12 mm
02	15 mm
03	17 mm
At number 04 and upward x 5 [mm]	

Execution	
-	Cylindrical bore
K	Tapered bore 1:12

Lubrication groove	
W33	Lubrication groove with 3 bores in outer ring

Coating with ATCoat	
A11	Inner and outer ring ATCoated
A15	Inner and outer ring ATCoated, rolling elements and cage corrosion resistant*
A 21	Inner ring ATCoated
A 31	Outer ring ATCoated

Precision classes and radial clearance	
P6, P63, SPC1X, SPC2X, P52, P53, SP(C1)	

Cage	
M	Machined brass cage located on rolling elements
M1	Machined brass cage, riveted, located on rolling elements
M1A	Machined brass cage, riveted, located on outer ring
MA	Machined brass cage located on outer ring
MB	Machined brass cage located on inner ring
P	Polyamide window type cage located on outer ring with lubrication groove in outer diameter of cage
PA	Polyamide window type cage, located on outer ring
PB	Polyamide window type cage, located on inner ring
PH	Polyamide window type cage, located on rolling elements

Designation system 52-900

*Corrosion protection depending on application, for further information please refer to main catalogue

7.1 Production Range IBC Precision Cylindrical Roller Bearings

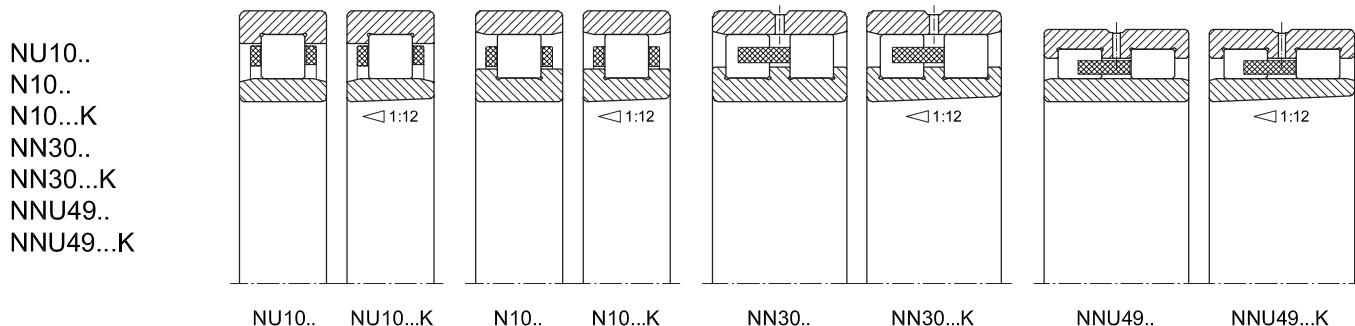

52-112

d mm	Production series											
	NU 10.../NU 10...K		N 10.../N 10...K		NN 30.../NN 30...K		NNU 49.../NNU 49...K					
	D	B	D	B	D	B	D	B				
	mm		mm		mm		mm					
10												
12												
15												
17												
20												
25	NU 1005	47	12									
30	NU 1006	55	13									
35	NU 1007	62	14									
40	NU 1008	68	15	N 1008	68	15						
45	NU 1009	75	16	N 1009	75	16						
50	NU 1010	80	16	N 1010	80	16	NN 3010	80	23			
55				N 1011	90	18	NN 3011	90	26			
60				N 1012	95	18	NN 3012	95	26			
65				N 1013	100	18	NN 3013	100	26			
70				N 1014	110	20	NN 3014	110	30			
75				N 1015	115	20	NN 3015	115	30			
80				N 1016	125	22	NN 3016	125	34			
85				N 1017	130	22	NN 3017	130	34			
90				N 1018	140	24	NN 3018	140	37			
95				N 1019	145	24	NN 3019	145	37			
100				N 1020	150	24	NN 3020	150	37	NNU 4920	140	40
105				N 1021	160	26	NN 3021	160	41	NNU 4921	145	40
110				N 1022	170	28	NN 3022	170	45	NNU 4922	150	40
120							NN 3024	180	46	NNU 4924	165	45
130							NN 3026	200	52	NNU 4926	180	50
140							NN 3028	210	53	NNU 4928	190	50
150							NN 3030	225	56	NNU 4930	210	60
160							NN 3032	240	60	NNU 4932	220	60
170							NN 3034	260	67	NNU 4934	230	60
180							NN 3036	280	74	NNU 4936	250	69
190							NN 3038	290	75	NNU 4938	260	69
200							NN 3040	310	82	NNU 4940	280	80
220										NNU 4944	300	80
240										NNU 4948	320	80
260												
280												

Table: Production Range IBC Precision Cylindrical Roller Bearings

14-303

7.2 IBC Precision Cylindrical Roller Bearings

NU10..
 N10...K
 N2..E
 NU2..E
 NN30...K
 NNU49...K

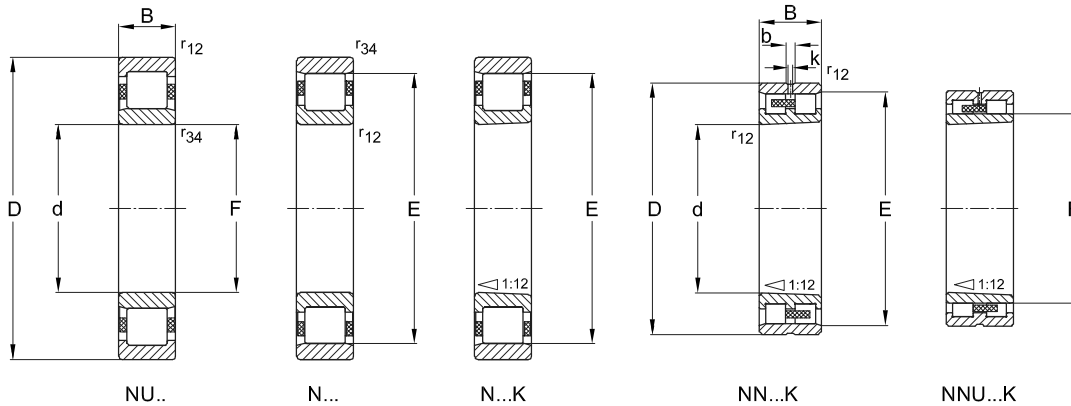

52-602

Primary dimensions			Basic designation	Basic load ratings		Speed ratings		Weight kg
d	D mm	B		C	C_o	$n_{bGrease}$ min ⁻¹	n_{bOil}	
25	47	12	NU1005	14 200	13 200	15 000	18 000	0.1
25	52	15	NU205.E	29 000	27 000	11 000	15 000	0.1
25	52	15	N205.E	29 000	27 000	11 000	15 000	0.1
30	55	13	NU1006	17 900	17 300	12 000	15 000	0.1
30	62	16	NU206.E	38 000	36 500	10 000	13 000	0.2
30	62	16	N206.E	38 000	36 500	10 000	13 000	0.2
35	62	20	NN3007K	40 000	52 000	14 000	16 000	0.3
35	62	14	NU1007	35 800	38 000	10 000	13 000	0.2
35	72	17	NU207.E	49 000	48 000	9 000	11 000	0.3
35	72	17	N207.E	49 000	48 000	9 000	11 000	0.3
40	68	15	N1008.K	27 000	31 000	15 000	17 000	0.2
40	68	21	NN3008K	43 000	57 000	12 000	14 000	0.3
40	68	15	NU1008	27 000	31 000	9 500	12 000	0.2
40	80	18	NU208.E	54 000	53 000	8 000	9 000	0.4
40	80	18	N208.E	54 000	53 000	8 000	9 000	0.4
45	75	16	N1009.K	31 000	34 000	14 000	16 000	0.2
45	75	23	NN3009K	50 000	67 000	11 000	13 000	0.4
45	75	16	NU1009	31 000	34 000	9 000	10 000	0.2
45	85	19	NU209.E	61 000	64 000	7 000	8 000	0.4
45	85	19	N209.E	61 000	64 000	7 000	8 000	0.4
50	80	16	N1010.K	35 000	40 000	13 000	15 000	0.3
50	80	23	NN3010K	54 000	74 000	10 000	12 000	0.4
50	80	16	NU1010	35 000	40 000	8 000	9 500	0.3
50	90	20	NU210.E	64 000	70 000	6 500	7 500	0.5
50	90	20	N210.E	64 000	70 000	6 500	7 500	0.5
55	90	18	N1011.K	41 000	50 000	12 000	14 000	0.4
55	90	26	NN3011K	70 000	98 000	9 500	11 000	0.6
55	90	18	NU1011	51 000	50 000	7 000	9 000	0.4
55	100	21	NU211.E	85 000	95 000	6 000	7 000	0.7
55	100	21	N211.E	85 000	95 000	6 000	7 000	0.7
60	95	18	N1012.K	44 000	55 000	13 000	13 000	0.4
60	95	26	NN3012K	74 000	110 000	9 000	10 000	0.7
60	95	18	NU1012	44 000	55 000	7 000	8 500	0.4
60	110	22	NU212.E	93 500	105 000	5 300	6 300	0.8
60	110	22	N212.E	93 500	105 000	5 300	6 300	0.8
65	100	20	N1013.K	45 000	58 000	11 000	12 000	0.4
65	100	26	NN3013K	77 000	116 000	8 500	9 500	0.7

IBC Precision Cylindrical Roller Bearings

NU10..
N10...K
N2..E
NU2..E
NN30...K
NNU49...K

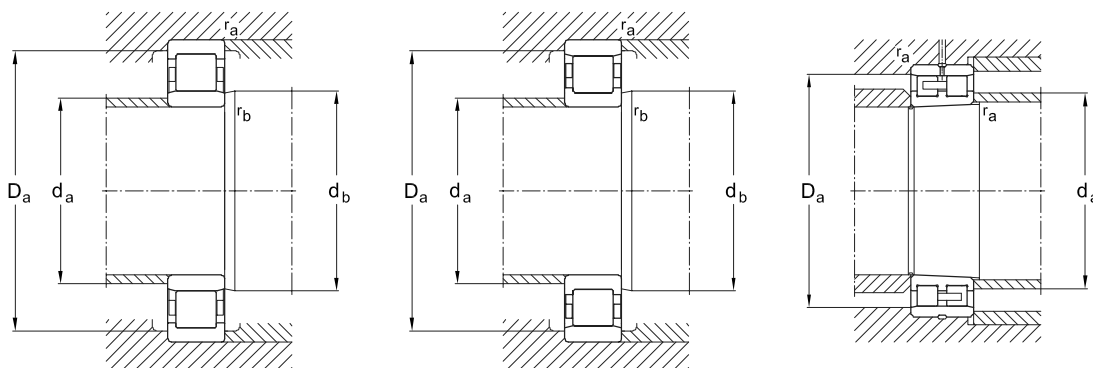

51-603

Basic designation	Dimensions							Abutment and fillet dimensions					
	E	F	b	k mm	r ₁₂	r ₃₄	s*	d _a _{min}	d _a _{max}	d _b _{min} mm	D _a _{max}	D _a _{min}	r _a _{max}
NU1005					0.6		2.0	27.0	43.0		29.0		0.6
NU205E		31.5			1.0	0.6	1.3	29.0	30.0	33.0	47.0		1.0
N205E	46.5				1.0	0.6	1.3	30.0	45.0		48.0	48.0	1.0
NU1006					1.0		2.0	34.0	50.0		35.0		1.0
NU206E		37.5			1.0	0.6	1.3	34.0	36.0	39.0	57.0		1.0
N206E	55.5				1.0	0.6	1.3	35.0	54.0		58.0	57.0	1.0
NN3007K					1.0		1.8	40.0			57.0	56.0	1.0
NU1007					1.0		1.0	39.0	57.0		41.0		1.0
NU207E		44.0			1.1	0.6	1.3	39.0	42.0	46.0	65.5		1.1
N207E	64.0				1.1	0.6	1.3	41.5	62.0		68.0	66.0	1.1
N1008.K					1.0	0.5		45.0	59.0		63.0	62.0	1.0
NN3008K					1.0		1.3	45.0			63.0	62.0	1.0
NU1008					1.0	0.6	2.4	44.0	63.0	49.0	63.0		1.0
NU208E		49.5			1.1	1.1	1.4	46.5	48.0	51.0	73.5		1.1
N208E	71.5				1.1	1.1	1.4	46.5	69.0		73.5	73.0	1.1
N1009.K					1.0	0.5		50.0	65.0		70.0	69.0	1.0
NN309K					1.0		2.0	50.0			70.0	69.0	1.0
NU1009					1.0	0.6	0.9	49.0	70.0	54.0	70.0		1.0
NU209E		54.5			1.1	1.1	1.2	51.5	53.0	56.0	78.5		1.1
N209E	76.5				1.1	1.1	1.2	51.5	74.0		78.5	78.0	1.1
N1010.K					1.0	0.5		55.0	70.0		75.0	74.0	1.0
NN3010K			3.7	2.0	1.0		2.0	55.0			75.0	74.0	1.0
NU1010					1.0	0.6	2.5	54.0	75.0	60.0	75.0		1.0
NU210E		59.5			1.1	1.1	1.5	56.5	57.0	62.0	83.5		1.1
N210E	81.5				1.1	1.1	1.5	56.5	79.0		83.5	84.0	1.1
N1011.K					1.1	0.6		61.5	79.0		83.5	82.0	1.1
NN3011K			3.7	2.0	1.1		2.0	61.5			83.5	82.0	1.0
NU1011					1.1	1.0	0.5	60.0	83.5	67.0	83.5		1.0
NU211E		66.0			1.5	1.1	1.0	61.5	64.0	68.0	92.0		1.5
N211E	90.0				1.5	1.1	1.0	63.0	88.0		93.5	92.0	1.5
N1012.K					1.1	0.6		66.5	84.0		88.5	87.0	1.1
NN3012K			3.7	2.0	1.1		2.0	66.5			88.5	87.0	1.0
NU1012					1.1	1.0	2.9	65.0	88.5	72.0	88.5		1.0
NU212E		72.0			1.5	1.5	1.4	68.0	70.0	74.0	102.0		1.5
N212E	100.0				1.5	1.5	1.4	68.0	98.0		102.0	102.0	1.5
N1013.K					1.1	0.6		71.5	89.0		93.5	92.0	1.1
NN3013K			3.7	2.0	1.1		2.0	71.5			93.5	92.0	1.0

* permissible axial displacement from normal position of one bearing ring to the other.

IBC Precision Cylindrical Roller Bearings

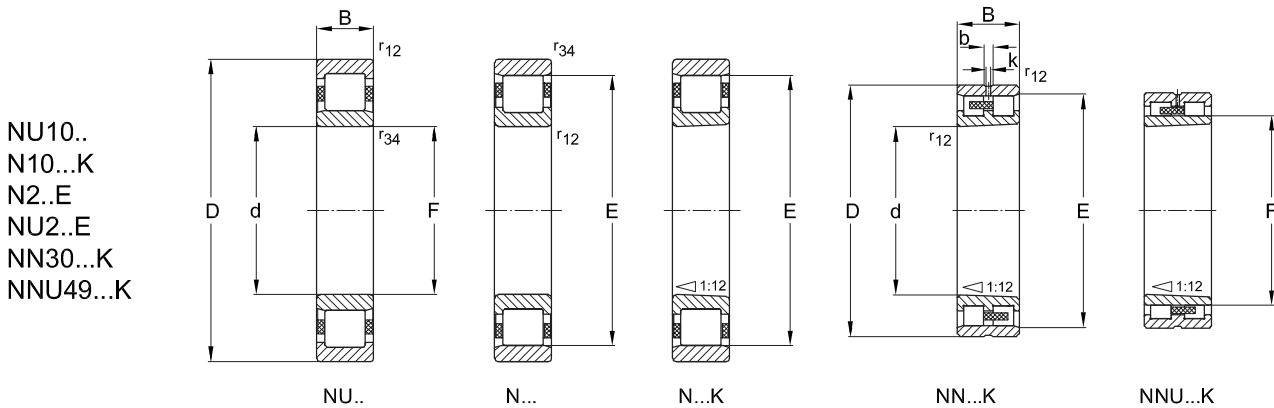

52-602

Primary dimensions			Basic designation	Basic load ratings		Speed ratings		Weight kg
d	D mm	B		C	C ₀	n _{bGrease} min ⁻¹	n _{bOil}	
65	100	18	NU1013	45 000	58 000	6 300	7 500	0.4
65	120	23	NU213.E	106 000	120 000	4 800	5 600	1.1
65	120	23	N213.E	106 000	120 000	4 800	5 600	1.1
70	110	20	N1014.K	63 000	78 000	1 000	11 000	0.6
70	110	30	NN3014K	87 000	148 000	7 500	8 500	1.0
70	110	20	NU1014	63 000	78 000	5 600	6 800	0.6
70	125	24	NU214.E	120 000	136 000	4 600	5 400	1.2
70	125	24	N214.E	120 000	136 000	4 600	5 400	1.2
75	115	22	N1015.K	64 000	80 000	9 000	10 000	0.7
75	115	30	NN3015K	97 000	153 000	7 000	8 000	1.1
75	115	20	NU1015	64 000	80 000	5 300	6 300	0.7
75	130	25	NU215.E	130 000	157 000	4 500	5 300	1.3
75	130	25	N215.E	130 000	157 000	4 500	5 300	1.3
80	125	22	N1016.K	77 000	95 000	8 500	9 000	0.9
80	125	34	NN3016K	120 000	184 000	6 700	7 500	1.5
80	125	22	NU1016	77 000	95 000	5 000	6 000	0.9
85	130	24	N1017.K	75 000	100 000	8 000	8 500	0.9
85	130	34	NN3017K	125 000	200 000	6 300	7 000	1.6
85	130	22	NU1017	75 000	100 000	4 800	5 600	0.9
90	140	24	N1018.K	85 000	110 000	7 500	8 000	1.2
90	140	37	NN3018K	140 000	214 000	6 000	6 700	2.0
90	140	24	NU1018	95 000	110 000	4 500	5 400	1.2
95	145	24	N1019.K	90 000	120 000	7 000	7 800	1.3
95	145	37	NN3019K	143 000	230 000	5 600	6 300	2.1
95	145	24	NU1019	90 000	120 000	4 200	5 000	1.3
100	140	40	NNU4920K	129 000	255 000	5 600	6 300	1.9
100	150	24	N1020.K	95 000	130 000	6 700	7 500	1.3
100	150	37	NN3020K	152 000	250 000	5 300	6 000	2.2
100	150	24	NU1020	95 000	130 000	4 000	4 800	1.3
105	145	40	NNU4921K	130 000	260 000	5 300	6 100	2.0
105	160	26	N1021.K	112 000	153 000	6 300	7 000	1.7
105	160	41	NN3021K	192 000	310 000	5 000	5 600	2.8
105	160	26	NU1021	112 000	153 000	3 800	4 500	1.7
110	150	40	NNU4922K	132 000	270 000	5 100	6 000	2.0
110	170	28	N1022.K	130 000	180 000	5 600	6 500	2.0
110	170	45	NN3022K	226 000	365 000	4 800	5 300	3.6
110	170	28	NU1022	130 000	180 000	3 600	4 300	2.1

IBC Precision Cylindrical Roller Bearings

NU10..
N10...K
N2..E
NU2..E
NN30...K
NNU49...K

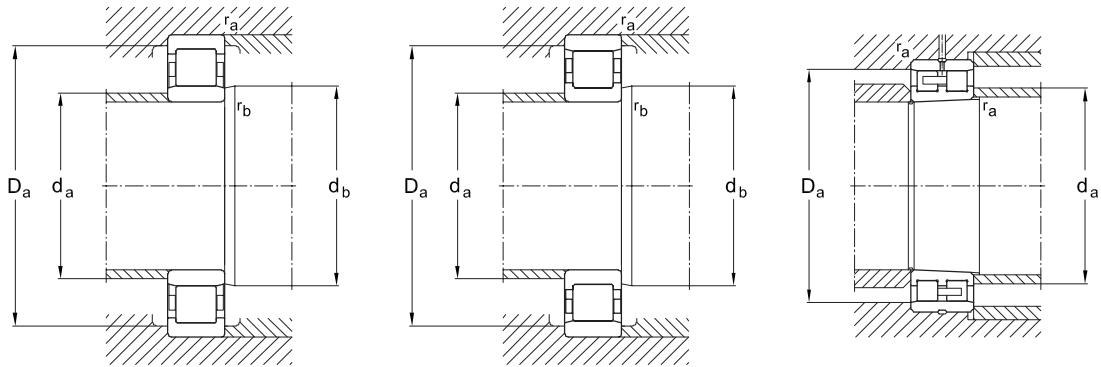

51-603

Basic designation	Dimensions							Abutment and fillet dimensions					
	E	F	b	k mm	r ₁₂	r ₃₄	s*	d _{a_min}	d _{a_max}	d _{b_min} mm	D _{a_max}	D _{a_min}	r _{a_max}
NU1013					1.1	1.0	2.9	70.0	93.5	77.0	93.5		1.0
NU213E		78.5			1.5	1.5	1.4	73.0	76.0	81.0	112.0		1.5
N213E	108.5				1.5	1.5	1.4	73.0	106.0		112.0	111.0	1.5
N1014.K	100.0				1.1	0.6		76.5	98.0		103.5	101.0	1.1
NN3014K	100.0		5.5	3.0	1.1		2.5	76.5			103.5	101.0	1.0
NU1014					1.1	1.0	3.0	75.0	103.5	82.0	103.5		1.0
NU2014E		83.5			1.5	1.5	1.2	78.0	111.0	86.0	117.0		1.5
N214E	113.5				1.5	1.5	1.2	78.0	111.0		117.0	116.0	1.5
N1015.K	105.0				1.1	0.6		81.5	102.0		108.5	106.0	1.1
NN3015K	105.0		5.5	3.0	1.1		2.5	81.5			108.5	106.0	1.0
NU1015					1.1	1.0	3.0	80.0	108.5	87.0	108.5		1.0
NU215E		88.5			1.5	1.5	1.2	83.0	86.0	91.0	122.0		1.5
N215E	118.5				1.5	1.5	1.2	83.0	116.0		122.0	121.0	1.5
N1016.K	113.0				1.1	0.6		86.5	110.0		118.5	114.0	1.1
NN3016K	113.0		5.5	3.0	1.1		3.0	86.5			118.5	114.0	1.0
NU1016					1.1	1.0	3.3	85.0	118.5	94.0	118.5		1.0
N1017.K	118.0				1.1	0.6		91.5	115.0		123.5	119.0	1.1
NN3017K	118.0		5.5	3.0	1.1		2.5	91.5			123.5	119.0	1.0
NU1017					1.1	1.0	3.3	90.0	123.5	99.0	123.5		1.0
N1018.K	127.0				1.5	1.0		98.0	124.0		132.0	129.0	1.5
NN3018K	127.0		5.5	3.0	1.5		2.8	98.0			132.0	129.0	1.5
NU1018					1.5	1.1	3.5	96.5	132.0	106.0	132.0		1.5
N1019.K	132.0				1.5	1.0		103.0	129.0		137.0	134.0	1.5
NN3019K	132.0		5.5	3.0	1.5		2.8	103.0			137.0	134.0	1.5
NU1019					1.5	1.1	3.5	101.5	137.0	111.0	137.0		1.5
NNU4920K		113.0			1.1		2.0	106.0	112.0		134.0		1.0
N1020.K	137.0				1.5	1.0		108.0	134.0		142.0	139.0	1.5
NN3020K	137.0		5.5	3.0	1.5		2.8	108.0			142.0	139.0	1.5
NU1020					1.5	1.1	3.5	106.5	142.0	116.0	142.0		1.5
NNU4921K		118.0			1.1		1.5	111.0	117.0		139.0		1.0
N1021.K	146.0				2.0	1.0		114.0	143.0		151.0	148.0	2.0
NN3021K	146.0		5.5	3.0	2.0		1.8	114.0			151.0	148.0	2.0
NU1021					2.0	1.1	3.8	111.5	151.0	122.0	151.0		2.0
NNU4922K		123.0			1.1		1.5	116.0	122.0		144.0		1.0
N1022.K	155.0				2.0	1.0		119.0	152.0		161.0	157.0	2.0
NN3022K	155.0		5.5	3.0	2.0		3.8	119.0			161.0	157.0	2.0
NU1022					2.0	1.1	3.8	116.5	161.0	128.0	161.0		2.0

* permissible axial displacement from normal position of one bearing ring to the other.

IBC Precision Cylindrical Roller Bearings

NU10..
N10...K
N2..E
NU2..E
NN30...K
NNU49...K

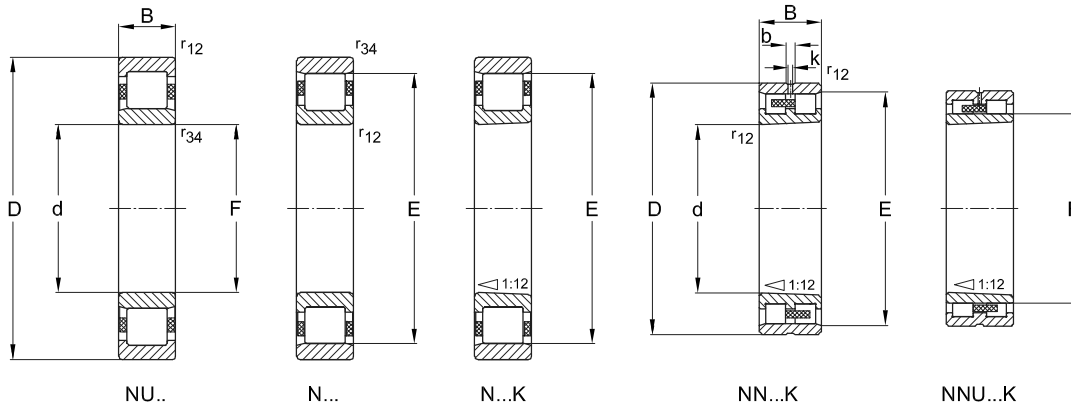

52-602

Primary dimensions			Basic designation	Basic load ratings		Speed ratings		Weight kg
d	D mm	B		C	C_o	$n_{bGrease}$ min ⁻¹	n_{bOil}	
120	165	45	NNU4924K	177 000	342 000	4 800	5 400	2.8
120	180	28	N1024.K	140 000	200 000	5 300	6 000	2.2
120	180	46	NN3024K	235 000	405 000	4 500	5 000	3.9
120	180	28	NU1024	140 000	200 000	3 400	4 000	2.2
130	180	50	NNU4926K	190 000	395 000	4 400	4 800	3.8
130	200	33	N1026.K	170 000	245 000	4 800	5 400	3.3
130	200	52	NN3026K	294 000	510 000	4 000	4 500	3.8
130	200	33	NU1026	170 000	245 000	3 000	3 600	3.3
140	190	50	NNU4928K	192 000	400 000	4 100	4 500	4.1
140	210	53	NN3028K	305 000	520 000	3 800	4 300	6.2
140	210	33	NU1028	180 000	260 000	3 100	3 500	4.0
150	210	60	NNU4930K	330 000	650 000	3 800	4 300	6.2
150	225	56	NN3030K	339 000	600 000	3 600	4 000	7.5
150	225	35	NU1030	200 000	310 000	2 700	3 300	4.9
160	220	60	NNU4932K	338 000	680 000	3 600	4 000	6.5
160	240	60	NN3032K	370 000	660 000	3 400	3 800	9.1
160	240	38	NU1032	240 000	340 000	2 500	3 100	6.0
170	230	60	NNU4934K	340 000	700 000	3 400	3 800	6.9
170	260	67	NN3034K	460 000	820 000	3 000	3 400	12.5
170	260	42	NU1034	280 000	420 000	2 300	2 800	7.9
180	250	69	NNU4936K	405 000	850 000	3 100	3 500	10.2
180	280	74	NN3036K	576 000	1 080 000	2 800	3 200	16.5
180	280	46	NU1036	340 000	500 000	2 100	2 600	10.4
190	260	69	NNU4938K	415 000	880 000	2 900	3 300	10.6
190	290	75	NN3038K	610 000	1 150 000	2 600	3 000	17.0
190	290	46	NU1038	365 000	540 000	2 000	2 500	10.0
200	280	80	NNU4940K	490 000	1 050 000	2 600	3 000	14.9
200	310	82	NN3040K	645 000	1 200 000	2 400	2 800	22.0
200	310	51	NU1040	400 000	600 000	1 900	2 400	14.0
220	300	80	NNU4944K	520 000	1 150 000	2 400	2 800	16.2
220	340	90	NN3044K	810 000	1 500 000	2 200	2 600	28.5
220	340	56	NU1044	500 000	750 000	1 800	2 200	18.5
240	320	80	NNU4948K	530 000	1 200 000	2 300	2 600	17.4
240	360	92	NN3048K	842 000	1 600 000	2 000	2 400	32.0
240	360	56	NU1048	530 000	840 000	1 700	2 000	20.0

IBC Precision Cylindrical Roller Bearings

NU10..
N10...K
N2..E
NU2..E
NN30...K
NNU49...K

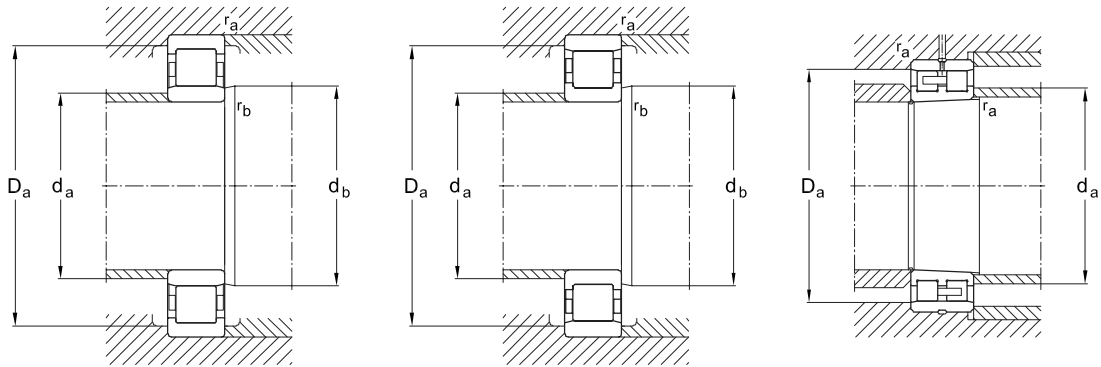

51-603

Basic designation	Dimensions							Abutment and fillet dimensions					
	E	F	b	k mm	r ₁₂	r ₃₄	s*	d _{a_min}	d _{a_max}	d _{b_min} mm	D _{a_max}	D _{a_min}	r _{a_max}
NNU4924K		134.5			1.1		1.5	126.0	133.0		159.0		1.0
N1024.K	165.0				2.0	1.0		129.0	162.0		171.0	167.0	2.0
NN3024K	165.0		5.5	3.0	2.0		3.8	129.0			171.0	167.0	2.0
NU1024					2.0	1.1	3.8	126.5	171.0	138.0	171.0		2.0
NNU4926K		146.0			1.5		2.0	137.0	145.0		173.0		1.5
N1026.K	182.0				2.0	1.0		139.0	179.0		191.0	183.0	2.0
NN3026K	182.0		8.3	4.5	2.0		3.8	139.0			191.0	183.0	2.0
NU1026					2.0	1.1	4.7	136.5	191.5	151.0	191.0		2.0
NNU4928K		156.0			1.5		2.0	147.0	155.0		183.0		1.5
NN3028K	192.0		8.3	4.5	2.0		3.8	149.0			201.0	194.0	2.0
NU1028					2.0	1.1	4.4	146.5	201.0	161.0	201.0		2.0
NNU4930K		168.5			2.0		2.3	159.0	167.0		201.0		2.0
NN3030K	206.0		8.3	4.5	2.1		4.0	161.0			214.0	208.0	2.0
NU1030					2.1	1.5	4.9	158.0	214.0	173.0	214.0		2.0
NNU4932K		178.5			2.0		2.3	169.0	177.0		211.0		2.0
NN3032K	219.0		8.3	4.5	2.1		5.0	171.0			229.0	221.0	2.0
NU1032					2.1	1.5	5.2	168.0	229.0	183.0	229.0		2.0
NNU4934K		188.5			2.0		2.3	179.0	187.0		221.0		2.0
NN3034K	236.0		8.3	4.5	2.1		5.0	181.0			249.0	238.0	2.0
NU1034					2.1	2.1	5.8	181.0	249.0	196.0	249.0		2.0
NNU4936K		202.0			2.0		2.6	189.0	200.0		241.0		2.0
NN3036K	255.0		11.1	6.0	2.1		5.0	191.0			169.0	257.0	2.0
NU1036					2.1	2.1	6.1	191.0	269.0	208.0	269.0		2.0
NNU4938K		212.0			2.0		2.6	199.0	210.0		251.0		2.0
NN3038K	265.0		11.1	6.0	2.1		5.0	201.0			279.0	267.0	2.0
NU1038					2.1	2.1	6.1	201.0	279.0	218.0	279.0		2.0
NNU4940K		225.0			2.1		3.4	210.0	223.0		270.0		2.1
NN3040K	282.0		11.1	6.0	2.1		6.5	211.0			299.0	285.0	2.0
NU1040	229.0				2.1	2.1	7.0	211.0	299.0	233.0	299.0		2.0
NNU4944K		245.0			2.1		3.4	230.0	243.0		290.0		2.1
NN3044K	310.0		13.9	7.5	3.0		7.4	233.0			327.0	313.0	2.5
NU1044					3.0	3.0	7.5	233.0	327.0	254.0	327.0		2.5
NNU4948K		265.0			2.1		4.0	250.0	263.0		310.0		2.1
NN3048K	330.0		13.9	7.5	3.0		7.4	253.0			347.0	333.0	2.5
NU1048					3.0	3.0	7.5	253.0	347.0	274.0	34.0		2.5

* permissible axial displacement from normal position of one bearing ring to the other.

IBC Precision Cylindrical Roller Bearings

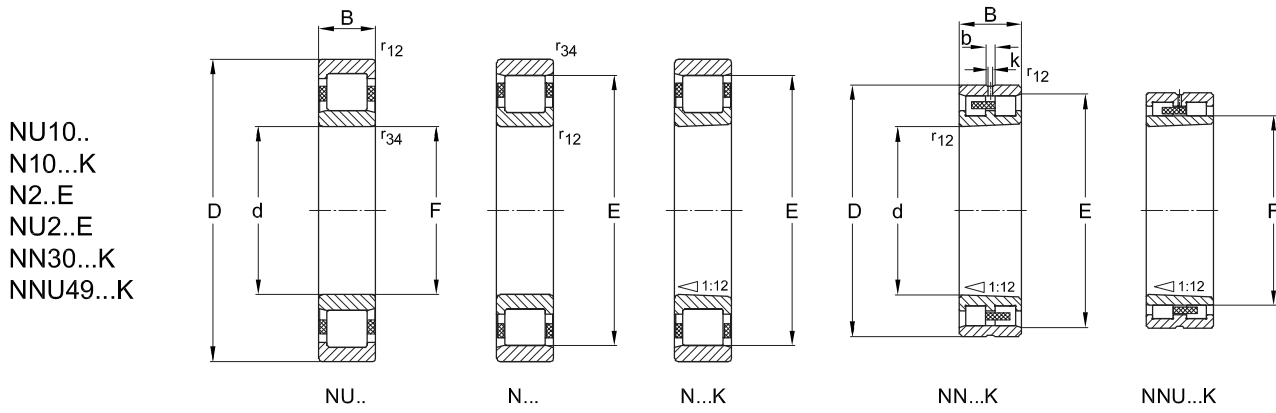

52-602

Primary dimensions			Basic designation	Basic load ratings		Speed ratings		Weight kg
d	D mm	B		C	C ₀	n _{bGrease} min ⁻¹	n _{bOil}	
260	360	100	NNU4952K	750 000	1 700 000	2 100	2 400	30.2
260	400	104	NN3052K	1 050 000	1 950 000	1 900	2 200	46.0
260	400	65	NU1052	650 000	1 000 000	1 500	1 800	29.0
280	380	100	NNU4956K	770 000	1 800 000	2 000	2 300	32.2
280	420	106	NN3056K	1 100 000	2 100 000	1 800	2 000	49.5
280	420	65	NU1056	680 000	1 100 000	1 400	1 700	32.5
300	420	118	NNU4960K	1 050 000	2 400 000	1 900	2 100	50.0
300	460	118	NN3060K	1 250 000	2 400 000	1 700	1 900	68.5
300	460	74	NU1060	890 000	1 400 000	1 200	1 500	44.0
320	440	118	NNU4964K	108 000	2 600 000	1 800	2 000	53.0
320	480	121	NN3064K	1 350 000	2 600 000	1 600	1 800	74.0
320	480	74	NU1064	900 000	1 450 000	1 150	1 400	48.5
340	460	118	NNU4968K	1 100 000	2 700 000	1 600	1 800	56.0
340	520	133	NN3068K	1 650 000	3 200 000	1 400	1 600	97.5
340	520	82	NU1068	1 100 000	1 800 000	1 100	1 350	65.0
360	480	118	NNU4972K	1 150 000	2 800 000	1 500	1 700	58.5
360	540	134	NN3072K	1 750 000	3 500 000	1 400	1 600	105.0
360	540	82	NU1072	1 150 000	1 850 000	1 050	1 300	67.5
380	520	140	NNU4976K	1 450 000	3 700 000	1 300	1 600	87.5
380	560	135	NN3076K	1 700 000	3 500 000	1 300	1 500	110.0
380	560	82	NU1076	1 200 000	2 000 000	1 000	1 200	71.0
400	540	140	NNU4980K	1 500 000	3 800 000	1 300	1 500	91.5
400	600	148	NN3080K	2 100 000	4 500 000	1 100	1 300	149.0
400	600	90	NU1080	1 380 000	2 320 000	950	1 150	92.5
420	560	140	NNU4984K	1 550 000	4 000 000	1 200	1 400	95.0
420	620	150	NN3084K	2 150 000	4 500 000	1 000	1 200	156.0
420	620	90	NU1084	1 400 000	2 450 000	900	1 100	96.0
440	600	160	NNU4988K	2 000 000	5 200 000	1 000	1 200	131.0
440	650	157	NN3088K	2 500 000	5 100 000	950	1 150	170.0
460	620	160	NNU4992K	2 150 000	5 500 000	1 000	1 200	137.0
460	680	163	NN3092K	2 600 000	5 400 000	950	1 150	204.0
480	650	163	NNU4996K	2 400 000	6 100 000	1 000	1 200	162.0
480	700	165	NN3096K	2 700 000	5 900 000	950	1 100	214.0



IBC Precision Cylindrical Roller Bearings

NU10..
N10...K
N2..E
NU2..E
NN30...K
NNU49...K

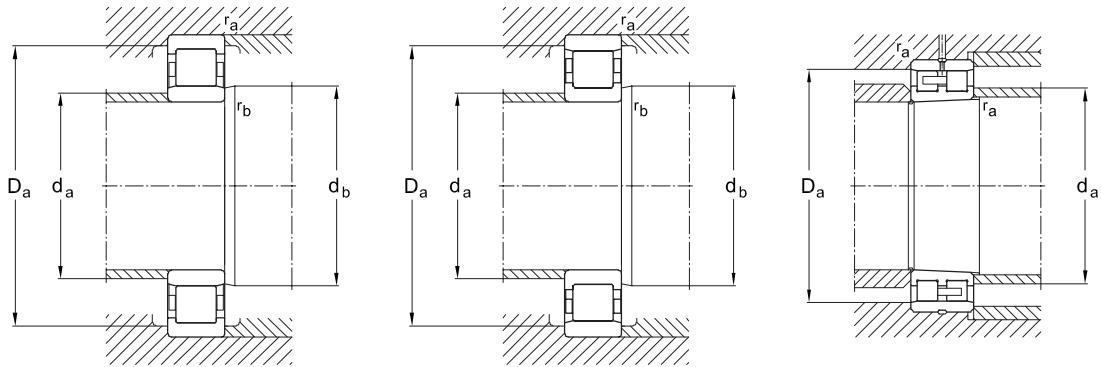

51-603

Basic designation	Dimensions							Abutment and fillet dimensions					
	E	F	b	k mm	r ₁₂	r ₃₄	s*	d _{a_min}	d _{a_max}	d _{b_min} mm	D _{a_max}	D _{a_min}	r _{a_max}
NNU4952K		292.0			2.1		4.0	270.0	289.0		350.0		2.1
NN3052K	364.0		13.9	7.5	4.0		7.4	276.0			384.0	367.0	3.0
NU1052		296.0			4.0	4.0	8.8	276.0	384.0	300.0	384.0		3.0
NNU4956K		312.0			2.1		5.0	290.0	309.0		370.0		2.1
NN3056K	384.0		13.9	7.5	4.0		12.4	296.0			404.0	387.0	3.0
NU1056		216.0			4.0	4.0	8.8	296.0	404.0	320.0	404.0		3.0
NNU4960K		339.0			3.0		5.0	312.0	335.0		408.0		2.5
NN3060K	418.0		16.7	9.0	4.0		8.9	316.0			444.0	421.0	3.0
NU1060		340.0			4.0	4.0	9.7	316.0	444.0	344.0	444.0		3.0
NNU4964K		359.0			3.0		5.5	333.0	355.0		427.0		2.5
NN3064K	438.0		16.7	9.0	4.0		8.9	336.0			464.0	442.0	3.0
NU1064		360.0			4.0	4.0	9.7	336.0	464.0	364.0	464.0		3.0
NNU4968K		379.0			3.0		5.5	353.0	375.0		447.0		2.5
NN3068K	473.0		16.7	9.0	5.0		10.9	360.0			500.0	477.0	4.0
NU1068		385.0			5.0	5.0	10.8	360.0	500.0	389.0	500.0		4.0
NNU4972		399.0			3.0		5.5	373.0	395.0		467.0		2.5
NN3072K	493.0		16.7	9.0	5.0	5.0	10.9	380.0			520.0	497.0	4.0
NU1072		405.0			5.0	5.0	10.8	380.0	520.0	410.0	520.0		4.0
NNU4976K		426.0			4.0		5.5	396.0	421.0		504.0		3.0
NN3076K	513.0		16.7	9.0	5.0	5.0	11.9	400.0			540.0	518.0	4.0
NU1076		425.0			5.0	5.0	10.8	400.0	540.0	430.0	540.0		4.0
NNU4980K		446.0			4.0		5.5	416.0	441.0		524.0		3.0
NN3080K	549.0		17.7	9.5	5.0	5.0	12.5	418.0			580.0	553.0	4.0
NU1080		450.0			5.0	5.0	14.0	420.0	580.0	455.0	580.0		4.0
NNU4984K		466.0			4.0		5.5	436.0	461.0		544.0		3.0
NN3084K	569.0		17.7	9.5	5.0		12.0	440.0			600.0	574.0	4.0
NU1084		470.0			5.0	5.0	14.0	440.0	600.0	475.0	600.0		4.0
NNU4988K		490.0			4.0		5.5	457.0	483.0		584.0		3.0
NN3088K	597.0		22.3	12.0	6.0	6.0	13.0	467.0			624.0	600.0	5.0
NNU4992K		510.0			4.0		5.5	477.0	503.0		604.0		3.0
NN3092K	624.0		22.3	12.0	6.0	6.0	13.5	487.0			654.0	627.0	5.0
NNU4996K		534.0			5.0		5.5	497.0	523.0		624.0		4.0
NN3096K	644.0		22.3	12.0	6.0	6.0	13.5	505.0			674.0	647.0	5.0

* permissible axial displacement from normal position of one bearing ring to the other.

8. Designation of IBC Thrust Ball Bearings

511..
512..

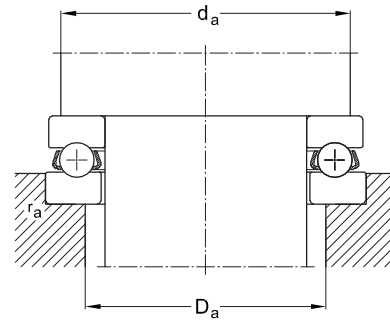
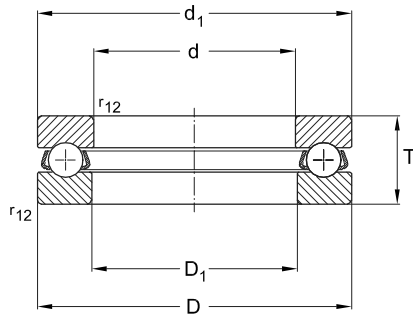

43-100

ACC	511	14	JCN	A15
	511	07	2GS	
	511	34	F	P6
	512	08		P5
AC-	511	10		P6 . A11

Material	
-	Steel rollers 100 Cr6
CR	Ceramic rollers Si ₃ N ₄
AC-	Rings ATCoated
ACC-	Rings ATCoated + balls Si ₃ N ₄

Series	
511..	
512..	

Bore code	
00	10 mm
02	15 mm
01	12 mm
03	17 mm
At number 04 and upwards x 5 [mm]	

Cage	
-	Pressed steel
F	Steel massive bonderized
JCN	Pressed steel Ni-coated
MP	Brass massive

ATCoated thin dense chrome	
A11	Washers ATCoated
A15	Washers ATCoated, rolling elements and cage corrosion resistant*

Quality	
P6	ISO 6
P5	ISO 5
P4	ISO 4

Special versions	
2 WS	Two shaft washers
2 GS	Two housing washers

Designation system 43-900

*Corrosion protection depending on application, for further information please refer to main catalogue

8.1 IBC Thrust Ball Bearings

511..
512..

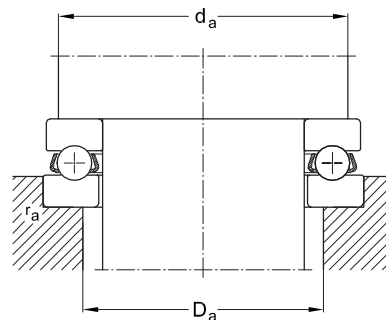
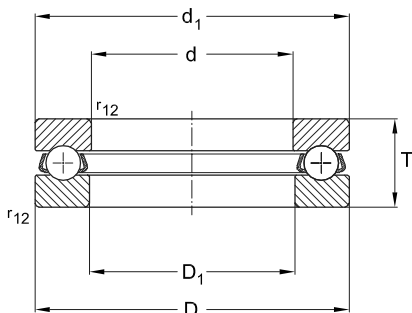

43-100

Single direction thrust ball bearings can only accommodate axial loads, only in one direction and no radial loads. As they are separable their three parts the shaft washer, the ball and cage assembly and the housing washer can be mounted separately.

Dimensions

The boundary dimensions are according to ISO 104-1979 (AFBMA standard 24.1) thrust bearings with flat back faces and DIN 711.

Misalignment

Not permitted.

Tolerances

IBC thrust ball bearings are manufactured to normal tolerances as well as to higher accuracy, P6, P5 due to DIN 620, part 3.

Cage

The cages are made out of pressed steel. Special executions (brass) on request.

Executions

Standard: rings made of steel or these ATCoated (wear and corrosion protection)

Minimum load

In order to assure satisfactory rolling condition despite the inertia forces acting on balls and cage a minimum load $F_{a \min}$ should be applied avoiding skidding of balls:

$$F_{a \min} = f_{a \min} \left(\frac{n}{1000} \right)^2 \quad [\text{N}]$$

$f_{a \min}$ see data table next page 42

n [min⁻¹]

Recommended fits of adjacent parts:

shaft h6, js6; housing H8.

8.2 IBC Thrust Ball Bearings

511..
512..

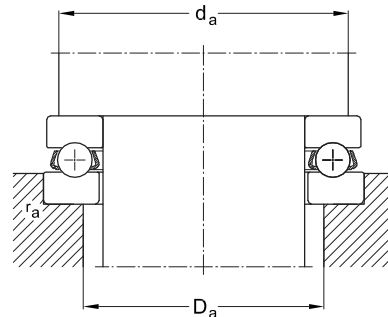
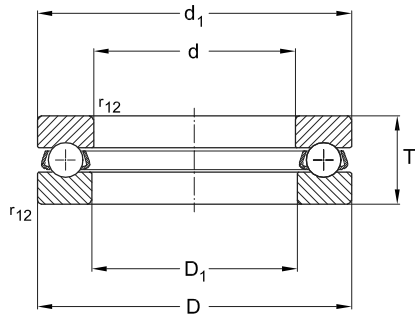

43-100

Primary dimensions			Basic designation	Dimensions					Basic load ratings		Load factor	Speed ratings		Weight m	
d	D	T		d ₁	D ₁	r ₁₂	d _a	D _a	r _{a,max}	C		C ₀	n _g		
mm			mm					N		f _{a,min}	Grease	Oil	kg		
											min ⁻¹				
10	24	9	51100	24	11	0.5	19	15	0.3	9 950	14 000	1	7 000	9 500	0.020
12	26	9	51101	26	13	0.5	21	17	0.3	10 400	15 300	0.8	6 700	9 000	0.022
15	28	9	51102	28	16	0.5	23	20	0.3	9 360	14 000	1	6 300	9 500	0.024
15	32	12	51202	32	17	1.0	25	22	0.6	16 500	25 000	3	5 300	7 000	0.046
17	30	9	51103	30	18	0.5	25	22	0.3	9 750	15 300	1	6 300	8 500	0.028
17	35	12	51203	35	19	1.0	28	24	0.6	17 200	27 500	4	5 000	6 700	0.053
20	35	10	51104	35	21	0.5	29	26	0.3	12 700	20 800	2	5 600	7 500	0.040
20	40	14	51204	40	22	1.0	32	28	0.6	22 500	37 500	7	4 500	6 000	0.082
25	42	11	51105	42	26	1.0	35	32	0.6	15 900	29 000	4	4 800	6 300	0.059
25	47	15	51205	47	27	1.0	38	34	0.6	27 600	50 000	13	4 000	5 300	0.120
30	47	11	51106	47	32	1.0	40	37	0.6	16 800	33 500	6	4 500	6 000	0.068
30	52	16	51206	52	32	1.0	43	39	0.6	25 500	47 500	11	3 600	4 800	0.144
35	52	12	51107	52	37	1.0	45	42	0.6	17 400	37 500	7	4 300	5 600	0.085
35	62	18	51207	62	37	1.5	51	46	1.0	35 100	67 000	23	3 000	4 000	0.220
40	60	13	51108	60	42	1.0	52	48	0.6	23 400	50 000	13	3 800	5 000	0.120
40	68	19	51208	68	42	1.5	57	51	1.0	46 800	98 000	50	2 800	3 800	0.270
45	65	14	51109	65	47	1.0	57	53	0.6	24 200	57 000	16	3 400	4 500	0.150
45	73	20	51209	73	47	1.5	62	56	1.0	39 000	80 000	34	2 600	3 600	0.320
50	70	14	51110	70	52	1.0	62	58	0.6	25 500	63 000	20	3 200	4 300	0.160
50	78	22	51210	78	52	1.5	67	61	1.0	49 400	106 000	60	2 400	3 400	0.390
55	78	16	51111	78	57	1.0	69	64	0.6	30 700	78 000	32	2 800	3 800	0.240
55	90	25	51211	90	57	1.5	76	69	1.0	61 800	134 000	94	1 900	2 800	0.610
60	85	17	51112	85	62	1.5	75	70	1.0	36 400	93 000	45	2 600	3 600	0.290
60	95	26	51212	95	62	1.5	81	74	1.0	62 400	140 000	100	1 900	2 800	0.690
65	90	18	51113	90	67	1.5	80	75	1.0	37 100	98 000	50	2 400	3 400	0.340
65	100	27	51213	100	67	1.5	86	79	1.0	63 700	150 000	120	1 800	2 600	0.770
70	95	18	51114	95	72	1.5	85	80	1.0	37 700	104 000	57	2 400	3 400	0.360
70	105	27	51214	105	72	1.5	91	84	1.0	65 000	160 000	130	1 800	2 600	0.810

IBC Thrust Ball Bearings

511..
512..

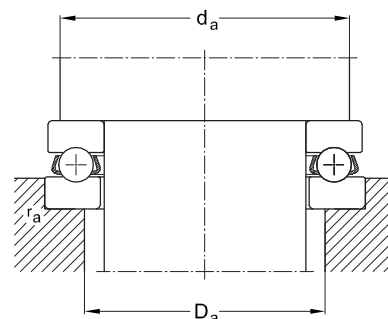
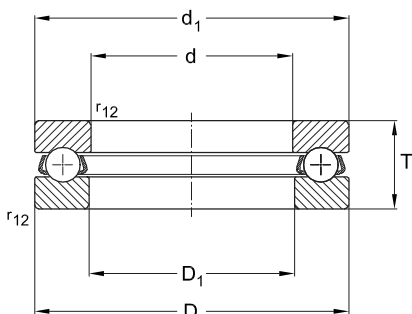

43-100

Primary dimensions			Basic designation	Dimensions						Basic load ratings		Load factor	Speed ratings		Weight m kg
d	D	T		d ₁	D ₁	r ₁₂	d _a	D _a	r _{a,max}	C	C ₀		f _{a,min}	Grease	
mm			mm						N		min ⁻¹				
75	100	19	51115	100	77	1.5	90	85	1.0	44 200	137 000	100	2 200	3 200	0.420
75	110	27	51215	110	77	1.5	96	89	1.0	67 600	170 000	150	1 700	2 400	0.860
80	105	19	51116	105	82	1.5	95	90	1.0	44 900	140 000	100	2 000	3 000	0.430
80	115	28	51216	115	82	1.5	101	94	1.0	76 100	190 000	190	1 700	2 400	0.950
85	110	19	51117	110	87	1.5	100	95	1.0	46 200	150 000	122	2 000	3 000	0.460
85	125	31	51217	125	88	1.5	109	101	1.0	97 500	250 000	340	1 600	2 200	1.290
90	120	22	51118	120	92	1.5	108	102	1.0	59 200	190 000	190	2 600	1 800	0.680
90	135	35	51218	135	93	2.0	117	108	1.0	119 000	300 000	480	2 000	1 500	1.770
100	135	25	51120	135	102	1.5	121	114	1.0	85 200	270 000	390	2 400	1 700	0.990
100	150	38	51220	150	103	2.0	130	120	1.0	124 000	320 000	540	1 800	1 300	2.360
110	145	25	51122	145	112	1.5	131	124	1.0	87 100	290 000	445	2 200	1 600	1.080
110	160	38	51222	160	113	2.0	140	130	1.0	130 000	360 000	680	1 700	1 200	2.570
120	155	25	51124	155	122	1.5	141	134	1.0	88 400	310 000	500	2 200	1 600	1.160
120	170	39	51224	170	123	2.0	150	140	1.0	140 000	400 000	840	1 600	1 100	2.860
130	170	30	51126	170	132	1.5	154	146	1.0	111 000	390 000	800	1 900	1 400	1.870
140	180	31	51128	178	142	1.5	164	156	1.0	111 000	400 000	835	1 800	1 300	2.070
150	190	31	51130	188	152	1.5	174	166	1.0	111 000	400 000	840	1 700	1 200	2.200
160	200	31	51132	198	162	1.5	184	176	1.0	112 000	425 000	950	1 700	1 200	2.330
170	215	34	51134	213	172	2.0	197	188	1.0	133 000	500 000	1350	1 600	1 100	3.310
180	225	34	51136	222	183	2.0	207	198	1.0	135 000	530 000	1500	1 500	1 000	3.480
190	240	37	51138	237	193	2.0	220	210	1.0	172 000	655 000	2250	1 400	950	4.060
200	250	37	51140	247	203	2.0	230	220	1.0	168 000	655 000	2300	1 400	950	4.240

9. Designation of IBC 60° Super Precision Angular Contact Thrust Ball Bearings

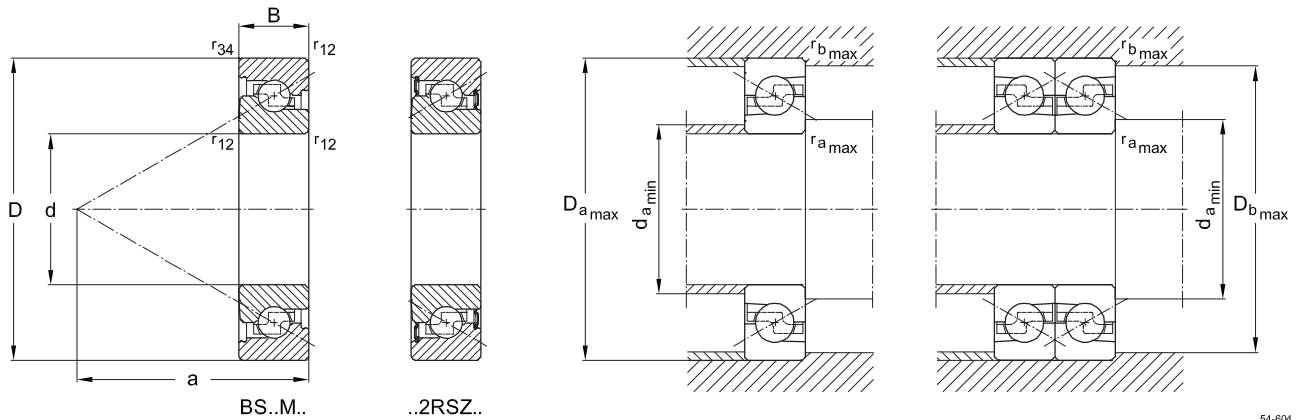

54-604

CB BS 75 M 110 S . P4A . D . UM . OX
 BS 30 M 62 /16 . 2RSZ P4A . UL
 AC BS 50 M 100 P4A . Q . UM
 - BS 25 M 62 /17 P4A . D . UH. A15 . GH62G

Material	
-	Steel balls 100 Cr6
CB	Ceramic balls Si ₃ N ₄
AC-	Rings ATCoated
ACC-	Rings ATCoated + balls Si ₃ N ₄

Series	
BS	60° Ang. Contact Ball Bearings

Bore code	
25 M	Metric bore 25 mm
150 I	Inch bore 1.50"

Dimension unit	
M	Metric
I	Inch

Outer diameter	
Only metric bearings are marked [mm]	

Bearing width	
Standard width not marked	
/17 = 17 mm width according to DIN 616	

(not all combinations are possible)

Sealing	
RSZ	Friction reduced sealing at one side
2RSZ	Friction reduced sealing at both sides

Lubrication	
-	50 % / GH62 (standard)
GN21G	30-35 % / GN21
OX	Corrosion protected

Coating with ATCoat	
A11	Inner and outer ring ATCoated
A15	Inner and outer ring ATCoated, rolling elements and cage corrosion resistant*
A 21	Inner ring ATCoated
A 31	Outer ring ATCoated

Axial clearance/preload, universal bearing	
UL	Light
UM	Medium
UH	High
U..	Special preload in daN
A...-	Axial clearance range

Arrangement	
-	Single bearing
D	Duplex set universal
T	Triplex set
Q	Quadruple set universal
Bearing arrangements (sets) see page 7	

Precision	
P4A	

Lubrication groove and bore	
S Oil lubrication via outer ring	

Designation system 54-900

*Corrosion protection depending on application, for further information please refer to main catalogue

Detailed information see catalogue TI-1-5010.2/E

9.1 60° Super Precision Angular Contact Thrust Ball Bearings

IBC angular contact thrust ball bearings have been developed to meet the demands of high thrust load for ball screw support application.

The large contact angle of 60° allows for high thrust load with high stiffness. The radial load should not extend 90 % of the preload.

As angular contact bearings can carry load only in one direction they therefore have to be adjusted to another bearing of the same kind.

The bearings are primarily supplied as single ones or in sets of 2 or 4 bearings to be mounted in back-to-back arrangements.

Angular contact thrust bearings are manufactured for universal matching, thus they can be rearranged and can be mounted in any arrangement.

As a standard single bearings have a medium or high preload, sets have a V-marking, single doesn't.

Precision grades: Bore and O.D. are manufactured to precision class P4A; axial runout S_d and S_{ia} are restricted to P2A (see page 48).

Preload

60°-Angular contact bearings are available with light, medium and high preload. They are apt for mounting in sets. For preloading we recommend the locknuts of series MMRB or MMRS (starting page 60). With tight fits the preload will be enhanced.

Material of rings and balls

Standard: bearing steel 100Cr6 (1.3505)

Options:

CB: ceramic Si_3N_4 with speed increase of 35 %

AC: rings thin dense chromium ATCoated (details to the option see page 65)

Cage: The one-piece glass fibre, reinforced polyamide cage is ball guided. As standard this is not designated. Temperature range -30 to 120 °C.

Lubrication:

The bearings are supplied with approved special greases as standard:

- For lower and medium speed: with the high viscose BearLub GH62
- For top speed range: with BearLub GN21. For this grease the speed limits are given in the data tables on page 47 and 56. For technical information on greases see page 74.

(Bearings with oil lubrication holes on request).

Sealing

Most of the bearings are supplied as open bearings and can be combined with labyrinth-seals of series S acc. to page 63.

The types on page 46 marked with + are also manufactured with non-touching seals .2RSZ.

More information:

See catalogue Screw Support Bearings TI-1-5012.2/E

Simply mounting

Whereas at the beginning (a) ball screw bearings had to be built in separately with other parts, now the ready-to-mount units are the state of art. The mounting of complete subassemblies eases and speeds up the mounting. The avoidance of an axial reference face in the housing bore simplifies surrounding parts (b).

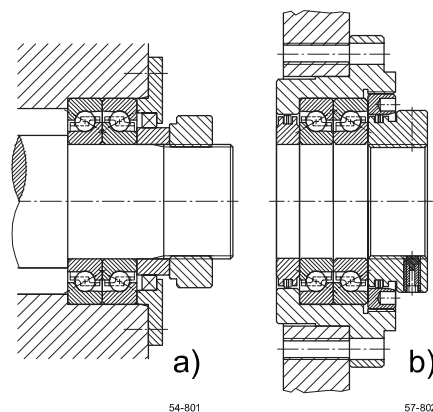

Arrangements

1) Fixed clamping at one end

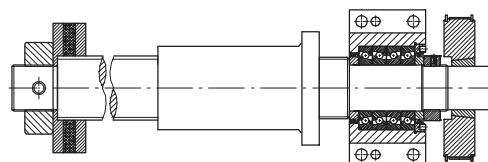

2) Fixed end and floating end combinations

- see page 57, 58 and front page.
- with spring preload at one side, see page 64

3) Fixed clamping at both ends

- for driven spindle

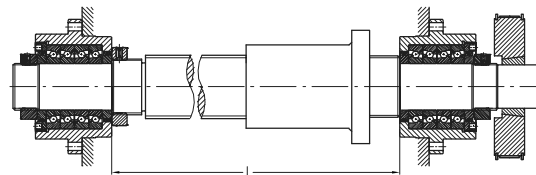

- for driven nut (see page 54), e.g. assembled with BNBUS 63QB130 2.M.M2 with integrated labyrinth seals, $n = 1000 \text{ min}^{-1}$. Spindle $\varnothing 40 \times 10$ fixed at ends (also available as BNBUS... with integrated lubricating system for the nut).

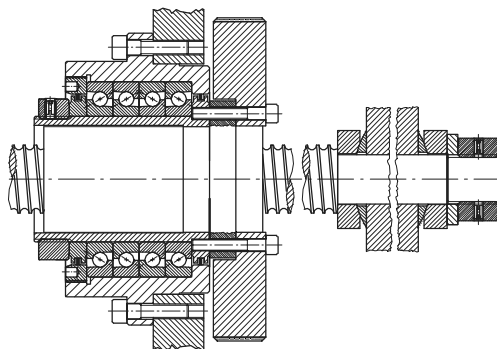

9.2 Super Precision 60° Angular Contact Thrust Ball Bearings metric, inch

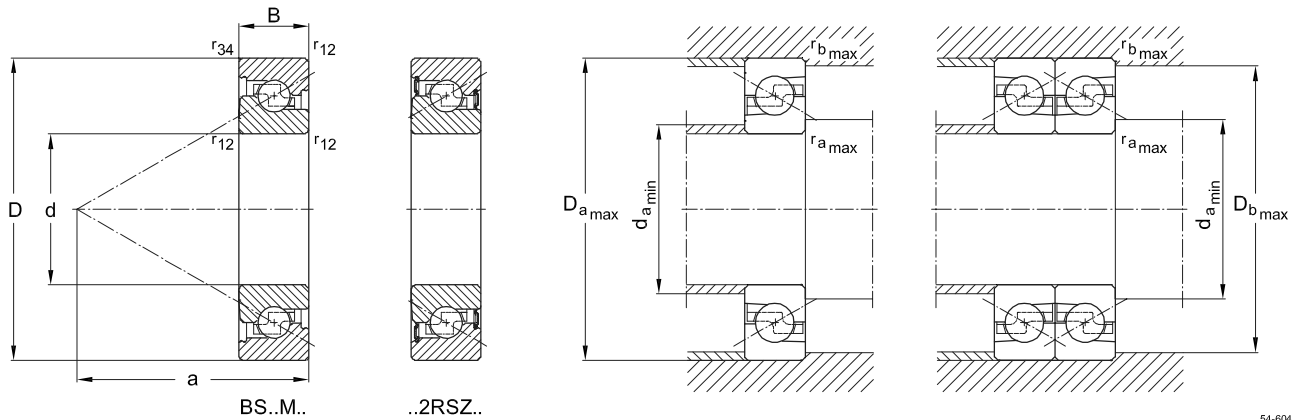

54-604

Dimensions						Basic designation	Abutment and fillet dimensions					Basic load ratings		Weight kg		
d	D	B	r _{1.2}	r ₃₄	a		r _a max	r _b max	d _a min	D _a max	D _b max	C _a	C _{0a}			
mm																
min																
~																
17	47	15	0.6	0.6	36.5	BS17M47	1.0	0.6	26	38	40	25 000	32100	0.13		
20	47	14	0.6	0.6	36	BS20M47/14*	1.0	0.6	28	38	40	25 000	32 100	0.14		
20	47	15	0.6	0.6	36.5	BS20M47	1.0	0.6	28	38	40	25 000	32 100	0.14		
25	52	15	1.0	0.6	39	BS25M52 +	1.0	0.6	34	44	45	26 500	37 000	0.22		
25	62	15	1.0	0.6	46.5	BS25M62 +	1.0	0.6	34	52	54	29 200	42 800	0.27		
25	62	17	1.0	0.6	47.5	BS25M62/17* +	1.0	0.6	34	52	54	29 200	42 800	0.27		
30	62	15	1.0	0.6	46	BS30M62 +	1.0	0.6	38	52	54	29 200	42 800	0.25		
30	62	16	1.0	0.6	47	BS30M62/16* +	1.0	0.6	38	52	54	29 200	42 800	0.25		
30	72	15	1.0	0.6	56	BS30M72 +	1.0	0.6	39	63	64	35 600	55 000	0.32		
30	72	19	1.0	0.6	58	BS30M72/19* +	1.0	0.6	39	63	64	35 600	55 000	0.32		
35	72	15	1.0	0.6	56	BS35M72 +	1.0	0.6	43	63	64	35 600	55 000	0.29		
35	72	17	1.0	0.6	57	BS35M72/17* +	1.0	0.6	43	63	64	35 600	55 000	0.34		
35	100	20	1.0	0.6	75	BS35M100 +	1.0	0.6	47	86	89	70 500	116 000	1.05		
40	72	15	1.0	0.6	56	BS40M72 +	1.0	0.6	48	63	64	35 600	55 000	0.28		
40	90	20	1.0	0.6	71.5	BS40M90 +	1.0	0.6	49	80	82	59 000	90 000	0.64		
40	90	23	1.0	0.6	73	BS40M90/23* +	1.0	0.6	49	80	82	59 000	90 000	0.72		
40	100	20	1.0	0.6	75	BS40M100 +	1.0	0.6	49	86	89	70 500	116 000	1.00		
45	75	15	1.0	0.6	60	BS45M75 +	1.0	0.6	53	65	67	37 900	61 400	0.29		
45	100	20	1.0	0.6	75	BS45M100 +	1.0	0.6	54	86	89	70 500	116 000	0.95		
50	90	20	1.0	0.6	71.5	BS50M90 +	1.0	0.6	59	80	82	59 000	90 000	0.60		
50	100	20	1.0	0.6	75	BS50M100 +	1.0	0.6	59	86	89	70 500	116 000	0.89		
55	90	15	1.0	0.6	73	BS55M90 +	1.0	0.6	64	78	81	40 700	74 400	0.42		
55	100	20	1.0	0.6	75	BS55M100 +	1.0	0.6	65	86	89	70 500	116 000	0.71		
55	120	20	1.0	0.6	88	BS55M120 +	1.0	0.6	65	106	108	80 800	137 000	1.43		
60	120	20	1.0	0.6	88	BS60M120 +	1.0	0.6	70	100	108	80 800	137 000	1.36		
75	110	15	1.0	0.6	89	BS75M110 +	1.0	0.6	85	98	100	44 500	93 800	0.48		
100	150	22.5	1.0	0.6	118	BS100M150 +	1.0	0.6	114	135	137	86 400	192 000	1.00		
127	180	22.225	1.0	0.6	143	BS127M180 +	1.0	0.6	140	165	168	85 200	239 300	1.24		
20	47	15.875	1.0	0.6	38	BS078 I	1.0	0.6	28	38	40	25 000	32 100	0.14		
23.838	62	15.875	1.0	0.6	50	BS093 I	1.0	0.6	32	52	54	29 200	42 800	0.25		
38.100	72	15.875	1.0	0.6	56	BS150 I	1.0	0.6	46	62	64	35 600	55 000	0.28		
44.475	76.2	15.875	1.0	0.6	60	BS175 I	1.0	0.6	52	66	68	37 900	61 400	0.30		

* Should no more be used in new applications.

+ with seals: suffix .2RSZ

Super Precision 60° Angular Contact Thrust Ball Bearings metric, inch

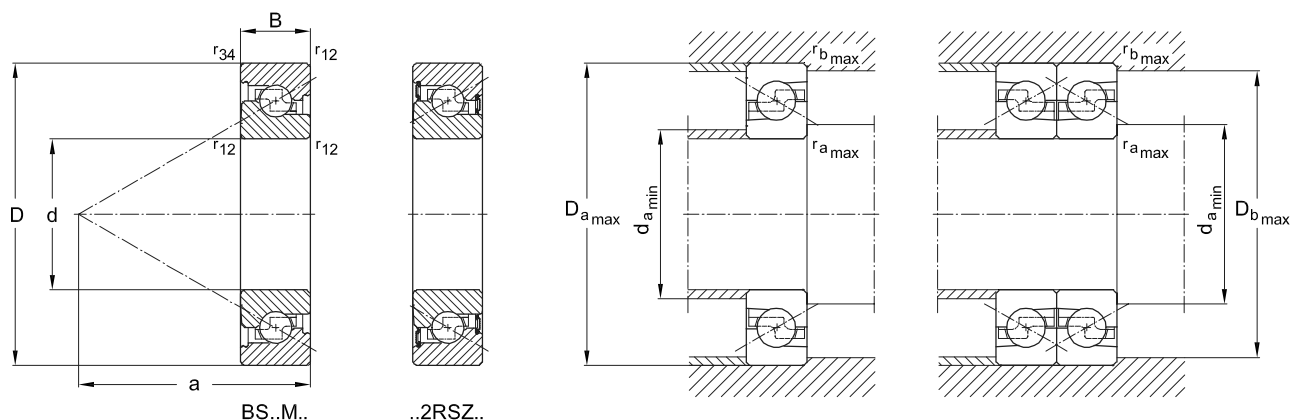

54-604

d mm	Preload F_v			Axial stiffness S_{ax}^*			Speed ratings (grease n_F^{**})			Drag torque M_r^{***}		
	L	M	H	L	M	H	L	M	H	L	M	H
	N			N/ μ m			min ⁻¹			Nm		
17	875	1 750	3 500	460	580	740	14 300	12 500	6 200	0.04	0.08	0.16
20	875	1 750	3 500	460	580	740	14 300	12 500	6 200	0.04	0.08	0.16
20	875	1 750	3 500	460	580	740	14 300	12 500	6 200	0.04	0.08	0.16
25	1 000	1 900	3 900	500	630	800	12 500	10 900	5 400	0.05	0.07	0.18
25	1 125	2 250	4 500	650	830	1 050	10 500	9 100	4 500	0.06	0.11	0.22
25	1 125	2 250	4 500	650	830	1 050	10 500	9 100	4 500	0.06	0.11	0.22
30	1 125	2 250	4 500	650	830	1 050	10 500	9 100	4 500	0.06	0.11	0.22
30	1 125	2 250	4 500	650	830	1 050	10 500	9 100	4 500	0.06	0.11	0.22
30	1 700	3 400	6 800	780	990	1 260	8 600	7 500	3 700	0.06	0.11	0.22
30	1 700	3 400	6 800	780	990	1 260	8 600	7 500	3 700	0.06	0.11	0.22
35	1 700	3 400	6 800	780	990	1 260	8 600	7 500	3 700	0.06	0.11	0.22
35	1 700	3 400	6 800	780	990	1 260	8 600	7 500	3 700	0.06	0.11	0.22
35	3 200	6 400	12 800	1 090	1 390	1 760	6 400	5 600	2 800	0.13	0.26	0.51
40	1 700	3 400	6 800	780	990	1 260	8 600	7 500	3 700	0.06	0.11	0.22
40	2 500	5 000	10 000	1 035	1 320	1 680	6 900	6 000	3 000	0.12	0.24	0.48
40	2 500	5 000	10 000	1 035	1 320	1 680	6 900	6 000	3 000	0.12	0.24	0.48
40	3 200	6 400	12 800	1 090	1 390	1 760	6 400	5 600	2 800	0.13	0.26	0.51
45	1 700	3 400	6 800	890	1 090	1 390	8 000	7 000	3 500	0.07	0.14	0.28
45	3 200	6 400	12 800	1 090	1 390	1 760	6 400	5 600	2 800	0.13	0.26	0.51
50	2 500	5 000	10 000	1 035	1 320	1 680	6 900	6 000	3 000	0.12	0.24	0.48
50	3 200	6 400	12 800	1 090	1 390	1 760	6 400	5 600	2 800	0.13	0.26	0.51
55	1 975	3 950	7 900	1 030	1 310	1 660	6 900	6 000	3 000	0.11	0.21	0.41
55	3 200	6 400	12 800	1 090	1 390	1 760	6 400	5 600	2 800	0.13	0.26	0.51
55	3 900	7 800	15 600	1 340	1 690	2 150	5 300	4 600	2 300	0.17	0.34	0.68
60	3 900	7 800	15 600	1 340	1 690	2 150	5 300	4 600	2 300	0.17	0.34	0.68
75	2 500	5 000	10 000	1 280	1 620	2 060	5 200	4 500	2 250	0.13	0.25	0.50
100	5 250	10 500	21 000	1 800	2 280	2 900	3 800	3 300	1 650	0.27	0.54	1.09
127	4 550	9 100	18 200	2 100	2 480	3 160	3 100	2 700	1 350	0.27	0.54	1.08
20			3 500			750			4 950			0.17
23.838			4 500			1 050			3 450			0.23
38.100			7 000			1 300			3 000			0.23
44.475			7 000			1 380			2 850			0.28

* For single bearing or Duplex set in O- or X-arrangement, for multiple arrangement see catalog TI-I-5010.2/E.

** Stated values are for Duplex sets in O-arrangement; for X-arrangement factor 0.6; for Quad sets QBT 0.75; QBC 0.7; max. rotational speed for L and M are valid for lubrication with GN21G

9.3 Tolerances of Super Precision 60° Angular Contact Thrust Bearings

Data table in μm

	Inner ring [mm]	Precision	\varnothing 0.6 to 10	10 18	18 30	30 50	50 80	80 120	120 150
Δd_{mp}	Max. deviation of the mean bore diameter from the nominal	P4A	-4	-4	-4	-5	-5	-6	-7.5
K_{ia}	Radial runout of assembled bearing inner ring	P4A	2.5	2.5	2.5	4	4	5	6
S_d	Side face runout referring to bore of inner ring	P2A	1.3	1.3	1.3	1.3	1.3	2.5	2.5
S_{ia}	Side face runout with reference to the raceway of the assembled bearing inner ring	P2A	1.3	1.3	2.5	2.5	2.5	2.5	2.5
ΔB_s	Deviation of single inner ring width	P4A, P2A	-200	-200	-200	-200	-250	-320	-370
V_{Bs}	Ring width variation	P4A	2.5	2.5	2.5	2.5	4	4	5

	Outer ring [mm]	Precision	\varnothing 18 to 30	30 50	50 80	80 120	120 150	150 180	180 250
ΔD_{mp}	Max. deviation of mean outside diameter to nominal	P4A, P2H	-5	-5	-5	-7.5	-9	-10	-10
K_{ea}	Radial runout of assembled bearing outer ring	P4A	4	5	5	5	7	7.5	10
S_D	Variation in inclination of outside cylindrical surface to outer ring side face	P2A	1.3	1.3	1.3	2.5	2.5	2.5	3.8
S_{ea}	Side face runout referring to raceway of assembled bearing outer ring	P2A	2.5	2.5	3.8	5	5	5	6.4

The width tolerances of the outer ring ($\Delta C_s, V_{C_s}$) correspond to those of inner ring ($\Delta B_s, V_{B_s}$).
The total width tolerance of a bearing set is the sum of the ones of the single bearings.

9.4 Proposed fits for Super Precision 60° Angular Contact Thrust Bearings

Nominal diameter d shaft [mm]	Precision	\varnothing incl.	-	10	18	30	50	80	120
Shaft tolerance Δd_1 fixed bearing	P4A	max. min.	-3 -7	-3 -7	-3 -7	-4 -8	-4 -9	-5 -10	-6 -12
Nominal diameter D housing [mm]	Precision	\varnothing incl.	18 30	30 50	50 80	80 120	120 150	150 180	180 250
Housing tolerance ΔD_G fixed bearing	P4A	max. min.	+5 0	+5 0	+5 0	+5 -1	+7 -1	+7 -2	+7 -2

Table: Summary of tolerances for adjacent parts for Super Precision 60° Angular Contact Thrust Bearings.

10. Designation of IBC Precision Bearing Units for Ball Screws

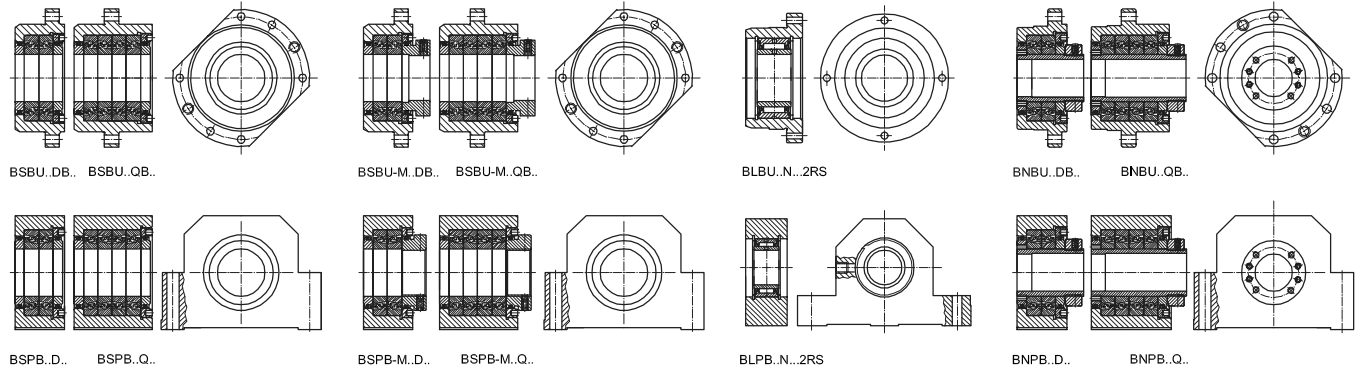

57-604

BS	BU	-M	25	D	B	88	.	M
ACC-	BS	BU	-M	40	Q	B	128	. QBT M A15 .GH62G
BS	PB		30	Q		50	.	L
BN	BU		63	Q	B	138	.	2 L -M2
BN	BU	S	75	Q	B	178	.	2 DB L -M2
BN	PB		95	D		105	.	2 M -M2
BL	PB		20	N		32	.	2RS

Material – Steel balls 100 Cr6 CB Ceramic balls Si ₃ N ₄ AC- Bearing rings ATCoat ACC- Balls Si ₃ N ₄ + ATCoat	Not all combinations are available	Lubrication – 50% /GH62 (standard) GN21G 30–35% /GN21
Bearing units for Ball Screws BS Fixed end units for spindle ends BN Bearing units for BS nuts BL Floating end units		Coating with ATCoat A11 Inner and outer ring ATCoated A15 Inner and outer ring ATCoated, rolling elements and cage corrosion resistant* A 21 Inner ring ATCoated A 31 Outer ring ATCoated
Execution BU Flange unit PB Pillow block unit		Mounting of adapter For BN..-units M2 As shown M1 Mounted when twisted 180°
Integrated lubrication S Integrated for Ball Screw nut		Preload/Bearing L Light preload M Medium preload H High preload
Integrated Locknut M Integrated – Locknut to integrated separately (MMRB)		Bearing arrangement DB, QBC Standard QBT  DT Tandem bearing for spring preloaded units
Bore code 25 Design/Metric bore 25 mm		Adapter Sleeve (DIN 69051) 1 Hole pattern 1 2 Hole pattern 2
Number of bearings D Duplex set Q Quadriple set N Needleroller for floating end units		Sealing – Labyrinth sealing 2RS Sealing for floating end units
Form of flange A Round B Flattened on both sides C Flattened on one side		
Reference dimension Flange seat diameter Center height of the pillow block		

Designation system 57-900

For fixed end bearing units for higher speed, also bearings with ceramic balls (CB) can be offered. On request also with ATCoat (AC) for bearings.

Detailed information please refer to catalogue TI-1-5010.2/E

*Corrosion protection depending on application, for further information please refer to main catalogue

Bearing units with more bearings on request, as well as special housings with integrated coupling and bearing units with integrated lubrication for BS nuts.

Lubrication

Bearings with standard lubrication GH 62; without suffix.
 Bearings with grease for higher speed: suffix GN21G.

10.1 IBC High Precision Flange Units for Spindle Ends of Ball Screws Support Bearings

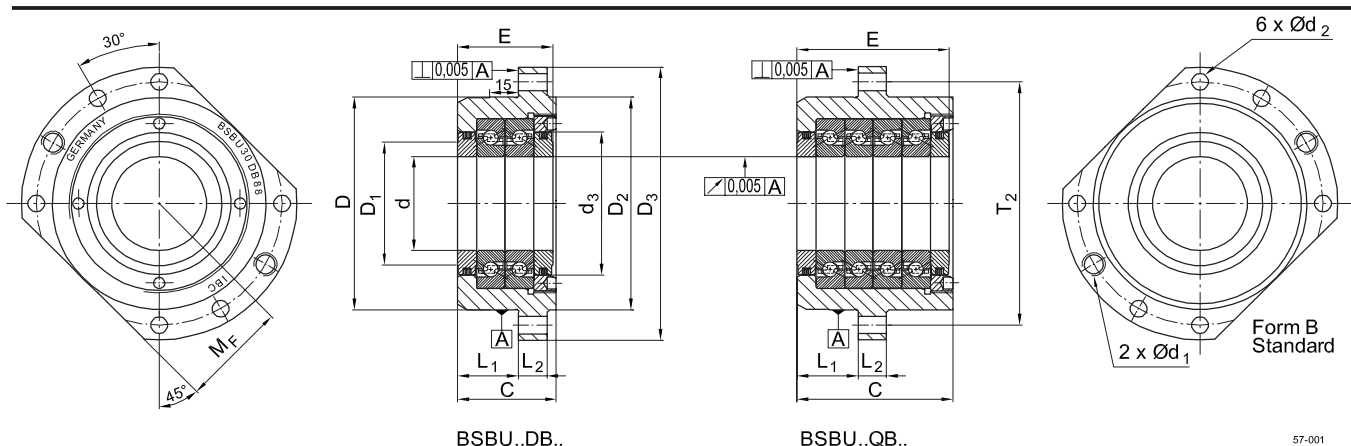

Shaft mm	Basic designation	d	D	M _F	C	E	d ₁	d ₂	d ₃	D ₁	D ₂	D ₃	Weight kg
		mm											

Medium Serie

17	BSBU 17 DB 64	17	64	32	47	44	M8	6.6	36	26	64	90	1.1
	BSBU 17 QB 64				77	74							1.7
20	BSBU 20 DB 64	20			47	44							1.1
	BSBU 20 QB 64				77	74							1.7
25	BSBU 25 DB 88	25	88	44	52	50	M12	9.2	50	40	88	120	2.3
	BSBU 25 QB 88				82	80							3.5
30	BSBU 30 DB 88	30			52	50							2.2
	BSBU 30 QB 88				82	80							3.4
	BSBU 30 DB 98		98	49	52	50			60	46	98	130	3.3
	BSBU 30 QB 98				82	80							4.7
35	BSBU 35 DB 98	35			52	50							3.2
	BSBU 35 QB 98				82	80							4.6
40	BSBU 40 DB 98	40			52	50				50			3.1
	BSBU 40 QB 98				82	80							4.5
45	BSBU 45 DB 98	45			52	50			60	55			3.8
	BSBU 45 QB 98				82	80							4.6
55	BSBU 55 DB 113	55	113	56.5	52	50			76	68	113	145	3.4
	BSBU 55 QB 113				82	80							5.1
75	BSBU 75 DB 138	75	138	69	54	50			99	86	138	170	4.1
	BSBU 75 QB 138				84	80							6.3

Heavy Serie

35	BSBU 35 DB 128	35	128	64	66	64	M14	11.4	76	66	128	165	6.3
	BSBU 35 QB 128				106	104							10.1
40	BSBU 40 DB 128	40			66	64							6.1
	BSBU 40 QB 128				106	104							9.7
45	BSBU 45 DB 128	45			66	64							6.0
	BSBU 45 QB 128				106	104							9.5
50	BSBU 50 DB 128	50			66	64							5.9
	BSBU 50 QB 128				106	104							9.3
55	BSBU 55 DB 148	55	148	74	66	64			99	86	148	185	8.2
	BSBU 55 QB 148				106	104							12.9
60	BSBU 60 DB 148	60			66	64							7.9
	BSBU 60 QB 148				106	104							12.5

Tolerances	d	D	E (Duplex)	E (Quad)
BSBU 17 DB/QB 64 – BSBU 30 DB/QB 88	0 / - 0.005	0 / - 0.013	0 / - 1.02	0 / - 1.52
BSBU 30 DB/QB 98 – BSBU 45 DB/QB 98	0 / - 0.005	0 / - 0.015	0 / - 1.02	0 / - 1.52
BSBU 55 DB/QB 113 – BSBU 60 DB/QB 148	0 / - 0.005	0 / - 0.018	0 / - 1.02	0 / - 1.52

Technical data see page 56.

Recommended locknuts serie MMRB... starting on page 60.

... for Spindle Ends of Ball Screw Support Bearings with integrated lock nut

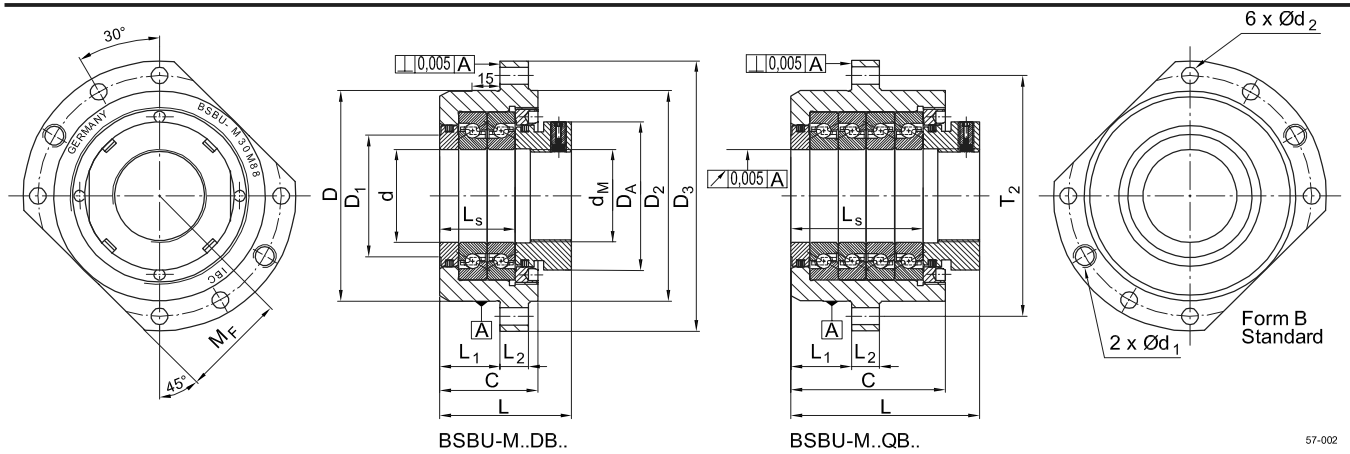

57-002

T ₂	L ₁	L ₂	D _A	L _S	L	Integrated locknut see page 62	Basic designation	Shaft mm
mm								
Medium Serie								
76	32	13	38	37	57	MMRS 17-36	BSBU-M 17 DB 64	17
				64	87		BSBU-M 17 QB 64	
				37	57	MMRS 20-36	BSBU-M 20 DB 64	20
				67	87		BSBU-M 20 QB 64	
102		15	58	40	65	MMRS 25-50	BSBU-M 25 DB 88	25
				70	95		BSBU-M 25 QB 88	
				40	65	MMRS 30-50	BSBU-M 30 DB 88	30
				70	95		BSBU-M 30 QB 88	
113			70	40	68	MMRS 30-60	BSBU-M 30 DB 98	
				70	98		BSBU-M 30 QB 98	
				40	68	MMRS 35-60	BSBU-M 35 DB 98	35
				70	98		BSBU-M 35 QB 98	
				40	68	MMRS 40-60	BSBU-M 40 DB 98	40
				70	98		BSBU-M 40 QB 98	
				40	68	MMRS 45-60	BSBU-M 45 DB 98	45
				70	98		BSBU-M 45 QB 98	
129			80	40	70	MMRS 55-76	BSBU-M 55 DB 113	55
				70	100		BSBU-M 55 QB 113	
154			105	40	70	MMRS 75-99	BSBU-M 75 DB 138	75
				70	100		BSBU-M 75 QB 138	
Heavy Serie								
146	43.5	17	80	52	82	MMRS 35-76	BSBU-M 35 DB 128	35
				92	122		BSBU-M 35 QB 128	
				52	82	MMRS 40-76	BSBU-M 40 DB 128	40
				92	122		BSBU-M 40 QB 128	
				52	82	MMRS 45-76	BSBU-M 45 DB 128	45
				92	122		BSBU-M 45 QB 128	
				52	82	MMRS 50-76	BSBU-M 50 DB 128	50
				92	122		BSBU-M 50 QB 128	
166				52	82	MMRS 55-99	BSBU-M 55 DB 148	55
				92	122		BSBU-M 55 QB 148	
			105	52	82	MMRS 60-99	BSBU-M 60 DB 148	60
				92	122		BSBU-M 60 QB 148	

10.2 IBC High Precision Pillow Block Units for Spindle Ends of Ball Screw Support Bearings

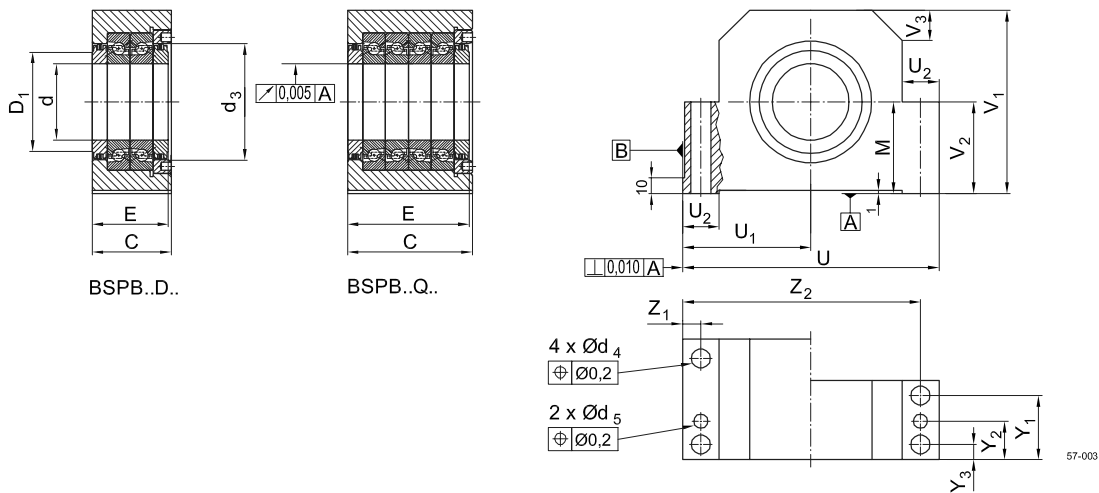

Shaft mm	Basic designation	d	M	C	E	d ₃	D ₁	U	U ₁	U ₂	V ₁	V ₂	V ₃	Weight kg
		mm												
Medium Serie														
17	BSPB 17 D 32	17	32	47	44	36	26	94	47	17	62	32	15	1.5
	BSPB 17 Q 32			77	74									2.6
20	BSPB 20 D 32	20		47	44									1.5
	BSPB 20 Q 32			77	74									2.6
25	BSPB 25 D 42	25	42	52	50	50	40	125	62.5	20	82	42		2.8
	BSPB 25 Q 42			82	80									4.6
30	BSPB 30 D 42	30		52	50									2.7
	BSPB 30 Q 42			82	80									4.5
	BSPB 30 D 50		50	52	50	60	46	136	68	20.5	95	50		3.9
	BSPB 30 Q 50			82	80									6.3
35	BSPB 35 D 50	35		52	50									3.8
	BSPB 35 Q 50			82	80									6.2
40	BSPB 40 D 50	40		52	50		50							3.7
	BSPB 40 Q 50			82	80									6.0
45	BSPB 45 D 50	45		52	50	60	55							3.6
	BSPB 45 Q 50			82	80									5.9
55	BSPB 55 D 65	55	65	52	50	76	68	154	77	23	118	65	30	4.5
	BSPB 55 Q 65			82	80									7.2
75	BSPB 75 D 65	75	65	54	50	99	86	174	87		129			5.0
	BSPB 75 Q 65			84	80									8.0
Heavy Serie														
35	BSPB 35 D 65	35	65	66	64	76	66	190	95	30	130	65	15	9.7
	BSPB 35 Q 65			106	104									15.9
40	BSPB 40 D 65	40		66	64									9.5
	BSPB 40 Q 65			106	104									15.7
45	BSPB 45 D 65	45		66	64									9.3
	BSPB 45 Q 65			106	104									15.4
50	BSPB 50 D 65	50		66	64									9.1
	BSPB 50 Q 65			106	104									15.1
55	BSPB 55 D 85	55	85	66	64	99	86	200	100		155	85		9.1
	BSPB 55 Q 85			106	104									15.1
60	BSPB 60 D 85	60		66	64									9.1
	BSPB 60 Q 85			106	104									15.1

Tolerances	d	M	U ₁	E (Duplex)	E (Quad)
BSPB 17 D/Q 32 – BSPB 30 D/Q 42	0 / - 0.005	0 / - 0.013	0 / - 0.013	0 / - 1.02	0 / - 1.52
BSPB 30 D/Q 50 – BSPB 45 D/Q 50	0 / - 0.005	0 / - 0.015	0 / - 0.015	0 / - 1.02	0 / - 1.52
BSPB 55 D/Q 65 – BSPB 60 D/Q 85	0 / - 0.005	0 / - 0.018	0 / - 0.018	0 / - 1.02	0 / - 1.52

Technical data see page 56.

Recommended locknuts serie MMRB... starting on page 60.

... for Spindle Ends of Ball Screw Support Bearings with integrated lock nut

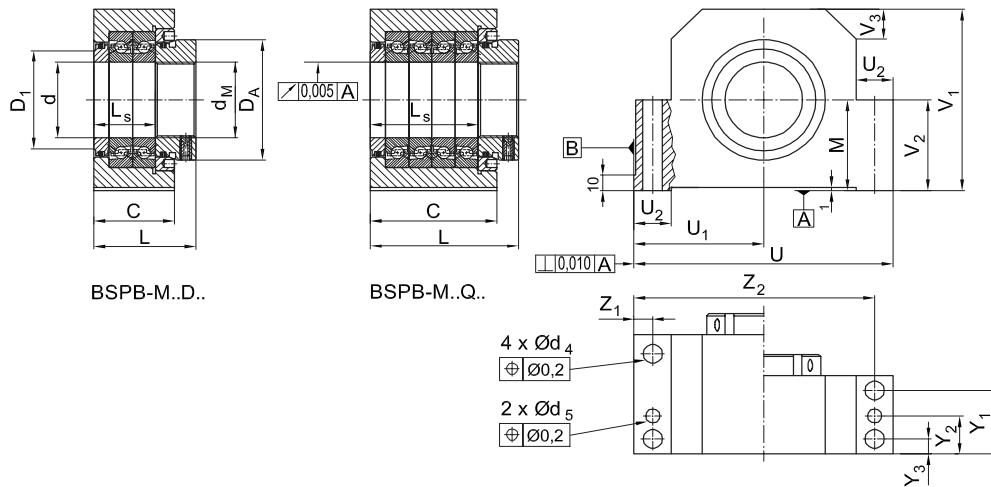

57-004

Y ₁	Y ₂	Y ₃	Z ₁	Z ₂	d ₄	d ₅	D _A	L _S	L	Integrated locknut see page 62	Basic designation	Shaft mm
mm												
Medium Serie												
38	22.0	9	8.5	85.5	9	7.8	38	37	57	MMRS 17-36	BSPB-M 17 D 32	17
68								67	87		BSPB-M 17 Q 32	
38								37	57	MMRS 20-36	BSPB-M 20 D 32	20
68								67	87		BSPB-M 20 Q 32	
42	25.0	10	10	115.0	11	9.8	58	40	65	MMRS 25-50	BSPB-M 25 D 42	25
72								70	95		BSPB-M 25 Q 42	
42								40	65	MMRS 30-50	BSPB-M 30 D 42	30
72								70	95		BSPB-M 30 Q 42	
42				126.0	13		70	40	68	MMRS 30-60	BSPB-M 30 D 50	
72								70	98		BSPB-M 30 Q 50	
42								40	68	MMRS 35-60	BSPB-M 35 D 50	35
72								70	98		BSPB-M 35 Q 50	
42								40	68	MMRS 40-60	BSPB-M 40 D 50	40
72								70	98		BSPB-M 40 Q 50	
42								40	68	MMRS 45-60	BSPB-M 45 D 50	45
72								70	98		BSPB-M 45 Q 50	
40.5	26.0	11.5	11.5	142.5			80	40	70	MMRS 55-76	BSPB-M 55 D 65	55
70.5								70	100		BSPB-M 55 Q 65	
40.5				162.5			105	40	70	MMRS 75-99	BSPB-M 75 D 65	75
70.5								70	100		BSPB-M 75 Q 65	
Heavy Serie												
53	32.0	13	15	175.0	18	11.8	80	52	82	MMRS 35-76	BSPB-M 35 D 65	35
93								92	122		BSPB-M 35 Q 65	
53								52	82	MMRS 40-76	BSPB-M 40 D 65	40
93								92	122		BSPB-M 40 Q 65	
53								52	82	MMRS 45-76	BSPB-M 45 D 65	45
93								92	122		BSPB-M 45 Q 65	
53								52	82	MMRS 50-76	BSPB-M 50 D 65	50
93								92	122		BSPB-M 50 Q 65	
53				185.0				52	82	MMRS 55-99	BSPB-M 55 D 85	55
93								92	122		BSPB-M 55 Q 85	
53							105	52	82	MMRS 60-99	BSPB-M 60 D 85	60
93								92	122		BSPB-M 60 Q 85	

10.3 IBC High Precision Flange Units for Ball Screw Nuts

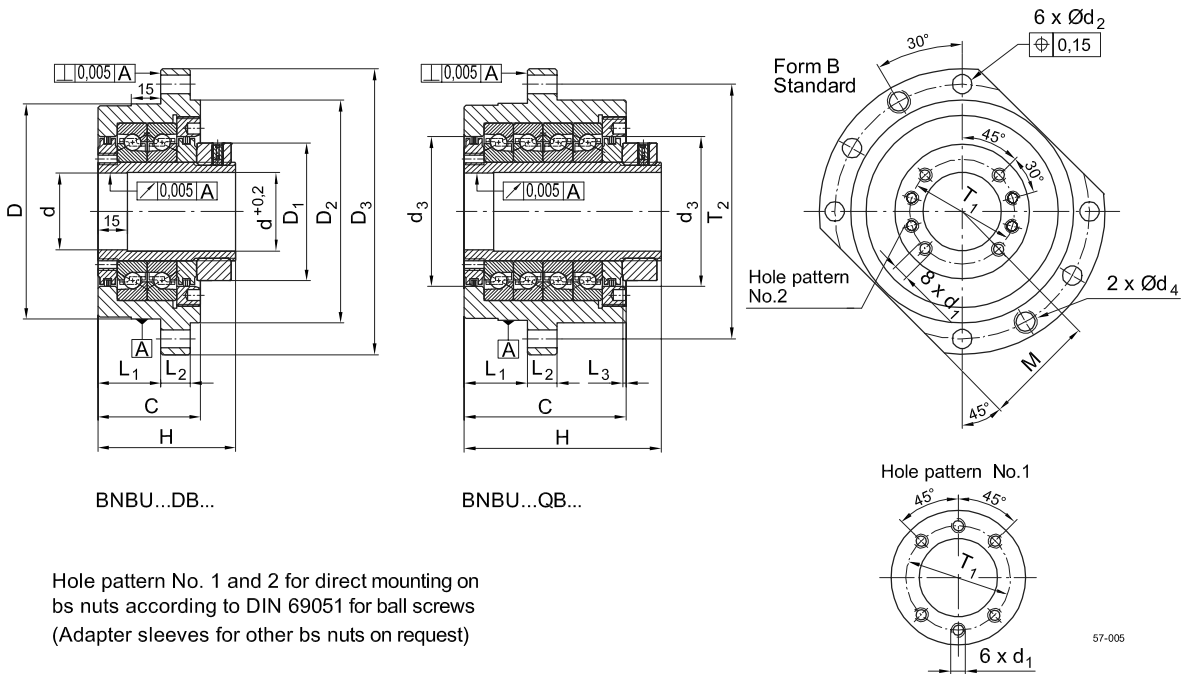

Hole pattern No. 1 and 2 for direct mounting on bs nuts according to DIN 69051 for ball screws (Adapter sleeves for other bs nuts on request)

KGT	Basic designation	d	D	M	C	H	d ₁	d ₂	d ₃	d ₄	D ₁	D ₂	D ₃	T ₁	T ₂	L ₁	L ₂	L ₃	Hole pattern
		mm																	
16x 5	BNBU 28 DB 98	28	98	49	52	70	M5	9.2	60	M12	70	98	130	38	113	32	15	2	1
20x 5	BNBU 36 DB 98	36			52	70	M6							47					
25x 5	BNBU 40 DB 113	40	113	56.5	52	70			76		80	113	145	51	129				
25x10	BNBU 40 QB 113				82	100													
32x 5	BNBU 50 DB 138	50	138	69	54	70	M8		99		105	138	170	65	154			4	
32x10	BNBU 50 QB 138				84	100													
40x 5	BNBU 63 DB 138	63			54	70								78					2
40x10	BNBU 63 QB 138				84	100													
50x 5	BNBU 75 DB 178	75	178	89	77	101	M10	11.4	132	M14	140	178	215	93	197	50	20		
50x10	BNBU 75 QB 178				122	146													
63x 5	BNBU 90 DB 210	90	210	105	77	105			162		175	210	248	108	230				
63x10	BNBU 90 QB 210				122	150													
63x20	BNBU 95 DB 210	95			77	105	M12							115					
	BNBU 95 QB 210				122	150													
80x10	BNBU 105 DB 210	105			77	105								125					
	BNBU 105 QB 210				122	150													

Technical data see page 27

Tolerances	Housing	d	D
BNBU 28 DB/QB 98 – BNBU 36 D/Q 98		+ 0.003 / - 0.010	0 / - 0.015
BNBU 40 DB/QB 113 – BNBU 105 D/Q 210		+ 0.003 / - 0.010	0 / - 0.018

For bearing units with integrated lubrication of ball screw nuts, please ask for separate data sheets (Serie BNBUS).

Adapter sleeves for other bs nuts on request.

Order example:

For a ballscrew Ø 63 x 10 with abutment dimension acc. to DIN 69051 a standard flange unit with hole pattern no. 2 and two bearings are needed as shown.

Medium preload is chosen: **BNBU 90DB210. 2.M.M2**

Mounting M1: connecting thread on right side, mounted opposite to mounting seat D.

10.4 IBC High Precision Pillow Block Units for Ball Screw Nuts

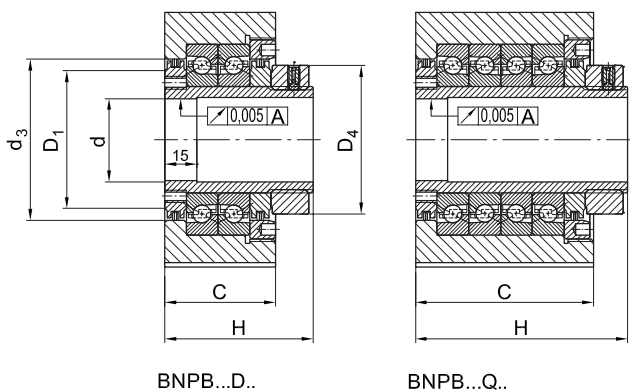

Hole pattern No. 1 and 2 for direct mounting on bs nuts according to DIN 69051 for ball screws (Adapter sleeves for other bs nuts on request)

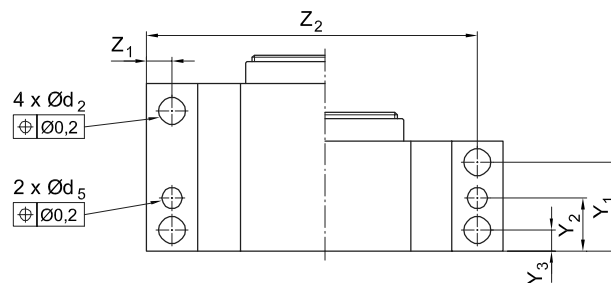
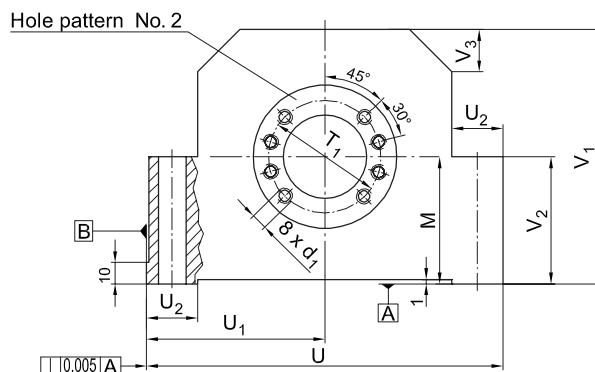
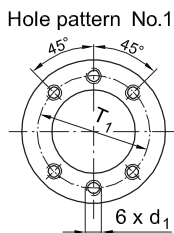

57-006

KGT do x P	Basic designation	d	M	C	H	d ₁ *	d ₃	d ₄	d ₅	D ₁	D ₄	T ₁	U	U ₁	U ₂	V ₁	V ₂	V ₃	Y ₁	Y ₂	Y ₃	Z ₁	Z ₂	B
		mm																						
16x 5	BNPB 28 D 50	28	50	52	70	M5	60	13	9.8	55	70	38	136	68	20.5	98	50	20	42	25.0	10	10	126.0	1
20x 5	BNPB 36 D 50	36		52	70	M6						47												
25x 5	BNPB 40 D 65	40	65	52	70		76			68	80	51	154	77	23	118	65		40.5	26.0	11.5	11.5	142.5	
25x10	BNPB 40 Q 65			82	100														70.5					
32x 5	BNPB 50 D 65	50		54	70	M8	99			89	105	65	174	87		129			40.5				162.5	
32x10	BNPB 50 Q 65			84	100														70.5					
40x 5	BNPB 63 D 65	63		54	70							78							40.5					2
40x10	BNPB 63 Q 65			84	100														70.5					
50x 5	BNPB 75 D 85	75	85	77	101	M10	132	18	11.8	114	140	93	230	115	30	170	85	30	57	37.0	17	15	215.0	
50x10	BNPB 75 Q 85			122	146														100					
63x 5	BNPB 90 D 105	90	105	77	105		162	21		140	175	108	280	140	35	207	105	50	57			17	263.0	
63x10	BNPB 90 Q 105			122	150														100					
63x20	BNPB 95 D 105	95		77	105	M12						115							57					
	BNPB 95 Q 105			122	150														100					
80x10	BNPB 105 D 105	105		77	105							125							57					
	BNPB 105 Q 105			122	150														100					

* preferable to be mounted with socket head cap screws to DIN 912, tensile strength class 8.8

Tolerances	Housing	d	M	U ₁
BSPB 28 D/Q 50 – BNPB 36 D/Q 50		+ 0.003 / 0.010	0 / - 0.015	0 / - 0.013
BSPB 40 D/Q 65 – BNPB 63 D/Q 65		+ 0.003 / 0.010	0 / - 0.018	0 / - 0.015
BSPB 75 D/Q 85 – BNPB 105 D/Q 105		+ 0.003 / 0.010	0 / - 0.018	0 / - 0.018

Adapter sleeves for other bs nuts on request.

Order example:

For a ballscrew Ø 80 x 10 heavy load with 4 bearings, adapter hole pattern No. 2 according to DIN 69051, light preload, mounted as shown above: **BNPB 105Q105 2.L.M2**

(Mounting M1: connecting thread on right side, mounted below outer locknut).

10.5 Technical Data Table of Flange and Pillow Block Units

BSBU..DB.. BSBU-M..DB.. BSPB..D.. BSPB-M..D..
 BSBU..QB.. BSBU-M..QB.. BSPB..Q.. BSPB-M..Q..

Basic designation		Axial capacity		Preload F_v			Ax. stiffness S_{ax}			Speed grease n_F			Drag troque M_r		
BSBU	BSPB	Ca	Coa	L	M	H	L	M	H	L	M	H	L	M	H
BSBU-M	BSPB-M	N		N			N/ μm			min ⁻¹			Nm		
Duplex Serie															
BSBU 17 DB 64	BSPB 17 D 32	25 000	32 000	875	1 750	3 500	450	570	730	14 300	12 500	6 200	0.08	0.16	0.32
BSBU 20 DB 64	BSPB 20 D 32														
BSBU 25 DB 88	BSPB 25 D 42	29 200	43 600	1 125	2 250	4 500	640	810	1 030	10 500	9 100	4 500	0.11	0.22	0.43
BSBU 30 DB 88	BSPB 30 D 42														
BSBU 30 DB 98	BSPB 30 D 50	35 600	55 000	1 700	3 400	6 800	770	970	1 240	8 600	7 500	3 700	0.11	0.22	0.43
BSBU 35 DB 98	BSPB 35 D 50														
BSBU 40 DB 98	BSPB 40 D 50														
BSBU 45 DB 98	BSPB 45 D 50	37 900	62 000	1 700	3 400	6 800	770	970	1 240	8 000	7 000	3 500	0.14	0.28	0.56
BSBU 55 DB 113	BSPB 55 D 65	40 700	74 000	1 975	3 950	7 900	1 020	1 300	1 640	6 900	6 000	3 000	0.22	0.42	0.82
BSBU 75 DB 138	BSPB 75 D 65	44 500	94 000	2 500	5 000	10 000	1 320	1 650	2 120	5 200	4 500	2 250	0.26	0.50	1.00
Heavy Serie															
BSBU 35 DB 128	BSPB 35 D 65	70 500	116 000	3 200	6 400	12 800	1 050	1 360	1 740	6 400	5 600	2 800	0.26	0.51	1.07
BSBU 40 DB 128	BSPB 40 D 65														
BSBU 45 DB 128	BSPB 45 D 65														
BSBU 50 DB 128	BSPB 50 D 65														
BSBU 55 DB 148	BSPB 55 D 85	80 800	137 800	3 900	7 800	15 600	1 320	1 650	2 120	5 300	4 600	2 300	0.34	0.68	1.36
BSBU 60 DB 148	BSPB 60 D 85														
Quadruplex Serie															
BSBU 17 QB 64	BSPB 17 Q 32	40 600	64 000	1 750	3 500	7 000	900	1 040	1 460	10 000	8 700	4 300	0.16	0.32	0.64
BSBU 20 QB 64	BSPB 20 Q 32														
BSBU 25 QB 88	BSPB 25 Q 42	47 500	86 000	2 250	4 500	9 000	1 280	1 620	2 060	7 300	6 300	3 100	0.22	0.43	0.86
BSBU 30 QB 88	BSPB 30 Q 42														
BSBU 30 QB 98	BSPB 30 Q 50	57 800	110 000	3 400	6 800	13 600	1 540	1 940	2 480	6 000	5 200	2 600	0.22	0.43	0.86
BSBU 35 QB 98	BSPB 35 Q 50														
BSBU 40 QB 98	BSPB 40 Q 50														
BSBU 45 QB 98	BSPB 45 Q 50	61 600	123 000	3 400	6 800	13 600	1 540	1 940	2 480	5 600	4 900	2 400	0.28	0.56	1.02
BSBU 55 QB 113	BSPB 55 Q 65	66 100	178 000	3 950	7 900	15 800	2 040	2 600	3 280	4 800	4 200	2 100	0.44	0.84	1.64
BSBU 75 QB 138	BSPB 75 Q 65	72 300	188 000	5 000	10 000	20 000	2 640	3 300	4 240	3 500	3 100	1 550	0.52	1.00	2.00
Heavy Serie															
BSBU 35 QB 128	BSPB 35 Q 65	114 500	232 000	6 400	12 800	25 600	2 100	2 720	3 480	4 450	3 900	1 950	0.52	1.02	2.04
BSBU 40 QB 128	BSPB 40 Q 65														
BSBU 45 QB 128	BSPB 45 Q 65														
BSBU 50 QB 128	BSPB 50 Q 65														
BSBU 55 QB 148	BSPB 55 Q 85	131 000	274 000	7 800	15 600	31 200	2 640	3 300	4 220	3 700	3 200	1 600	0.68	1.36	2.72
BSBU 60 QB 148	BSPB 60 Q 85														

with adapter sleeve for ball screw nuts acc. to DIN 69051 BNBU..DB., BNBU..QB., BNPB..D... BNPB..Q..

KGT	Basic designation		Axial capacity		Preload F_v			Ax. stiffness S_{ax}			Speed grease n_F			Drag troque M_r		
do x P	BNBU	BNPB	Ca	Coa	L	M	H	L	M	H	L	M	H	L	M	H
	BNBU-M	BNPB-M	N		N			N/ μm			min ⁻¹			Nm		
16x 5	BNBU 28 DB 98	BNPB 28 D 50	37 900	62 000	1 700	3 400	6 800	840	1 050	1 330	8 600	7 500	3 700	0.14	0.28	0.56
20x 5	BNBU 36 DB 98	BNPB 36 D 50	37 900	62 000	1 700	3 400	6 800	840	1 050	1 330	8 600	7 500	3 700	0.14	0.28	0.56
25x 5	BNBU 40 DB 113	BNPB 40 D 65	40 700	74 000	1 975	3 950	7 900	1 010	1 260	1 610	6 900	6 000	3 000	0.22	0.42	0.32
25x10	BNBU 40 QB 113	BNPB 40 Q 65	66 100	148 000	3 900	7 800	15 600	2 050	2 560	3 250	4 800	4 200	2 100	0.44	0.84	1.64
32x 5	BNBU 50 DB 138	BNPB 50 D 65	44 500	94 000	2 500	5 000	10 000	1 230	1 570	2 010	5 200	4 500	2 250	0.26	0.50	1.00
32x10	BNBU 50 QB 138	BNPB 50 Q 65	72 300	188 000	5 000	10 000	20 000	2 500	3 180	4 100	3 500	3 100	1 550	0.52	1.00	2.00
40x 5	BNBU 63 DB 138	BNPB 63 D 65	44 500	94 000	2 500	5 000	10 000	1 230	1 570	2 010	5 200	4 500	2 250	0.26	0.50	1.00
40x10	BNBU 63 QB 138	BNPB 63 Q 65	72 300	188 000	5 000	10 000	20 000	2 500	3 180	4 100	3 500	3 100	1 550	0.52	1.00	2.00
50x 5	BNBU 75 DB 178	BNPB 75 D 65	86 400	192 000	5 200	10 400	20 800	1 800	2 280	2 900	3 800	3 300	1 650	0.27	0.53	1.06
50x10	BNBU 75 QB 178	BNPB 75 Q 65	140 000	384 000	10 400	20 800	41 600	3 600	4 560	5 800	2 600	2 300	1 150	0.54	1.06	2.12
63x 5	BNBU 90 DB 210	BNPB 90 D 105	85 200	240 000	4 550	9 100	18 200	1 950	2 500	3 150	3 100	2 700	1 350	0.27	0.54	1.08
63x10	BNBU 90 QB 210	BNPB 90 Q 105	138 000	480 000	9 100	18 200	36 400	3 900	5 000	6 300	2 100	1 900	950	0.54	1.08	2.16
63x20	BNBU 95 DB 210	BNPB 95 D 105	85 200	240 000	4 550	9 100	18 200	1 950	2 500	3 150	3 100	2 700	1 350	0.27	0.54	1.08
	BNBU 95 QB 210	BNPB 95 Q 105	138 000	480 000	9 100	18 200	36 400	3 900	5 000	6 300	2 100	1 900	950	0.54	1.08	2.16
80x10	BNBU 105 DB 210	BNPB 105 D 105	85 200	240 000	4 550	9 100	18 200	1 950	2 500	3 150	3 100	2 700	1 350	0.27	0.54	1.08
	BNBU 105 QB 210	BNPB 105 Q 105	138 000	480 000	9 100	18 200	36 400	3 900	5 000	6 300	2 100	1 900	950	0.54	1.08	2.16

On request a speed increase of 35 % is possible by use of ceramic balls. Then the static capacity Coa will be reduced to 70 %.



10.6 IBC High Precision Floating End Units

Super Precision Pillow Block Bearing Units for Supporting Floating End of Shaft

BLPB..N.. 2RS

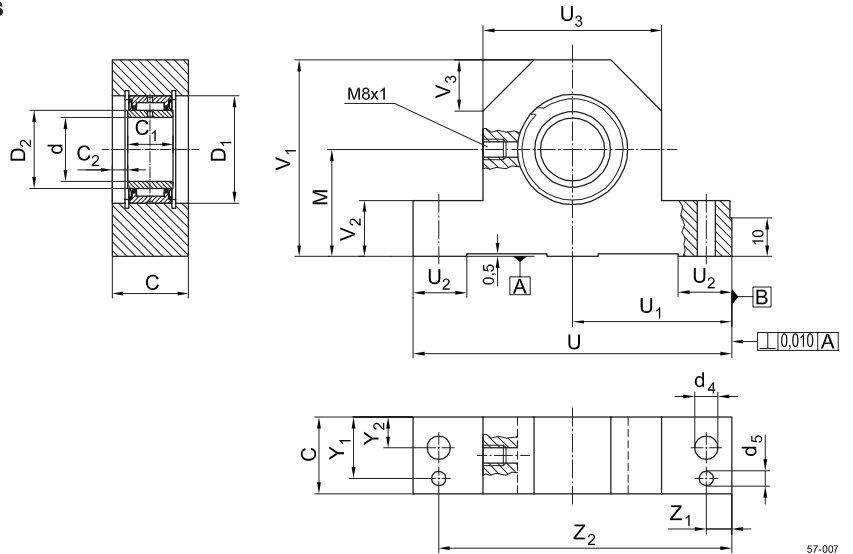

Tolerances	M	U ₁
BLPB 20 N 32	0 / -0.013	0 / -0.013
BLPB 25 N 42	0 / -0.013	0 / -0.013
BLPB 30 N 50	0 / -0.015	0 / -0.015
BLPB 40 N 65	0 / -0.018	0 / -0.018
BLPB 50 N 85	0 / -0.018	0 / -0.018

d according to PN DIN 620

Maximum speed see cartridge bearing unit

Shaft mm	Designation	d	M	C	C ₁	C ₂	D ₁	D ₂	U	U ₁	U ₂	U ₃	V ₁	V ₂	V ₃	Y ₁	Y ₂	Z ₁	Z ₂	d ₄	d ₅	C	Co
		mm																				N	
20	BLPB 20 N 32	20	32	30	18	6	37	25	94	47	16	56	59	15	15	24.0	12	8.5	85.5	9	5.8	17 300	19 900
25	BLPB 25 N 42	25	42	30	18	6	42	30	125	62.5	21	70	77	22	20	24.0	12	10	115	9	5.8	19 300	24 200
30	BLPB 30 N 50	30	50	30	18	6	47	35	136	68	21	80	88	28	20	24.0	12	10	126	9	5.8	21 100	28 500
40	BLPB 40 N 65	40	65	40	23	8.5	62	48	190	95	30	100	108	38	20	30.0	15	15	175	13	7.8	36 000	53 000
50	BLPB 50 N 85	50	85	40	23	8.5	72	58	200	100	30	110	138	48	30	30.0	15	15	185	13	7.8	40 000	64 000

Cartridge Bearing Units for Supporting Floating End of Shaft

BLBU..N... 2RS

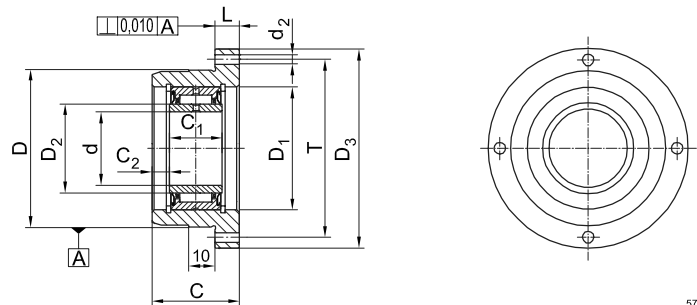

Shaft mm	Designation	d	D	C	C ₁	C ₂	D ₁	D ₂	D ₃	L	T	d ₂	n _{grease} min ⁻¹	C	Co
		mm											N		
10	BLBU 10 N 32	10	32	25	14	5.5	22	14	52	6	42	4.5	13 000	6 800	6 900
12	BLBU 12 N 35	12	35	25	14	5.5	24	16	55	6	45	4.5	12 000	7 600	8 300
17	BLBU 17 N 40	17	40	26	14	6	30	20	60	6	50	4.5	9 000	8 800	11 000
20	BLBU 20 N 50	20	50	30	18	6	37	25	70	8	60	4.5	7 500	17 300	19 900
25	BLBU 25 N 55	25	55	30	18	6	42	30	75	8	65	4.5	6 500	19 300	24 200
30	BLBU 30 N 60	30	60	32	18	6	47	35	80	8	70	4.5	5 500	21 100	28 500
35	BLBU 35 N 70	35	70	38	21	8.5	55	42	90	10	80	5.5	4 800	26 500	39 500
40	BLBU 40 N 80	40	80	43	23	10	62	48	110	10	95	5.5	4 200	36 000	53 000
45	BLBU 45 N 85	45	85	43	23	10	68	52	110	10	98	5.5	3 900	38 000	59 000
50	BLBU 50 N 90	50	90	44	23	10.5	72	58	120	10	105	5.5	3 500	40 000	64 000

Tolerances of Cartridge Bearing Units

Inner Diameter	d	PN DIN 620	
Cartridge Diameter	D	32 – 80	0 / -0.013
		85 – 90	0 / -0.015

10.7 Mounting Dimensions for Ball Screw Spindles

BSBU-M..DB..
BSPB-M..D..

BSBU-M..QB..
BSPB-M..Q..

BLBU..N..

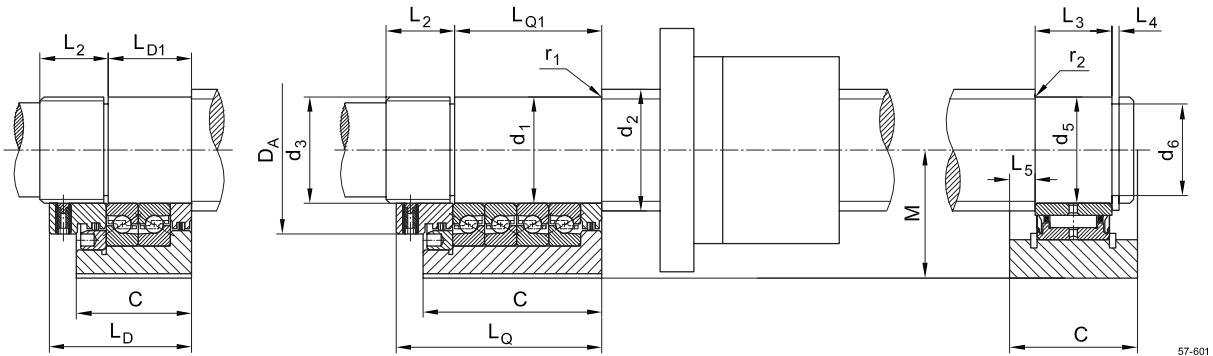

Basic designation	Fixed end										Centre height	Floating end						Basic designation
	d_1	d_2	d_3 4h/6h	D_A	L_D	L_{D1}	L_Q	L_{Q1}	L_2	r_{1max}	M	d_5 j5	d_6 h11	L_3	L_4	L_5	r_{2max}	

Medium Serie

BSPB-M 17.32	17	23	M 17 x 1	38	57	36	87	65	24	0.5	32	20	19.2	18	1.2	6	0.3	BLPB-20N32
BSPB-M 20.32	20	26	M 20 x 1															
BSPB-M 25.42	25	35	M 25 x 1.5	58	65	39	95	68	29	0.8	42	25	24	18	1.2	6	0.3	BLPB-25N42
BSPB-M 30.42	30	37	M 30 x 1.5															
BSPB-M 30.50	30	37	M 30 x 1.5	70	68	39	98	68	32	0.8	50	30	29	18	1.5	6	0.3	BLPB-30N50
BSPB-M 35.50	35	42	M 35 x 1.5															
BSPB-M 40.50	40	47	M 40 x 1.5															
BSPB-M 45.50	45	53	M 45 x 1.5															
BSPB-M 55.65	55	63	M 55 x 2	80	70	39	100	68	34	0.8	65	50	48.5	23	1.5	8.5	0.6	BLPB-50N85
BSPB-M 75.65	75	84	M 75 x 2	105														

Heavy Serie

BSPB-M 35.65	35	43	M 35 x 1.5	80	82	51	122	90	34	0.8	65	40	38.5	23	1.5	8.5	0.6	BLPB-40N65
BSPB-M 40.65	40	48	M 40 x 1.5															
BSPB-M 45.65	45	54	M 45 x 1.5															
BSPB-M 50.65	50	59	M 50 x 1.5															
BSPB-M 55.85	55	65	M 55 x 2	105	82	51		90	34		85	50	48.5	23	1.5	8.5	0.6	BLPB-50N85
BSPB-M 60.85	60	70	M 60 x 2															

The following cartridge units have the same dimensions as pillow block units:

Medium Serie

BSBU-M	BSPB-M	Tolerance d_1 [μ m]
BSBU-M 17.64	BSPB-M 17.32	-3 / -7
BSBU-M 20.64	BSPB-M 20.32	
BSBU-M 25.88	BSPB-M 25.42	-3 / -7
BSBU-M 30.88	BSPB-M 30.42	
BSBU-M 30.98	BSPB-M 30.50	-4 / -8
BSBU-M 35.98	BSPB-M 35.50	
BSBU-M 40.98	BSPB-M 40.50	
BSBU-M 45.98	BSPB-M 45.50	-4 / -8
BSBU-M 55.113	BSPB-M 55.65	-4 / -9
BSBU-M 75.138	BSPB-M 75.65	-4 / -9

Heavy Serie

BSBU-M 35.128	BSPB-M 35.65	-4 / -8
BSBU-M 40.128	BSPB-M 55.85	
BSBU-M 45.128	BSPB-M 45.65	
BSBU-M 50.128	BSPB-M 50.65	
BSBU-M 55.148	BSPB-M 55.85	-4 / -9
BSBU-M 60.148	BSPB-M 60.85	

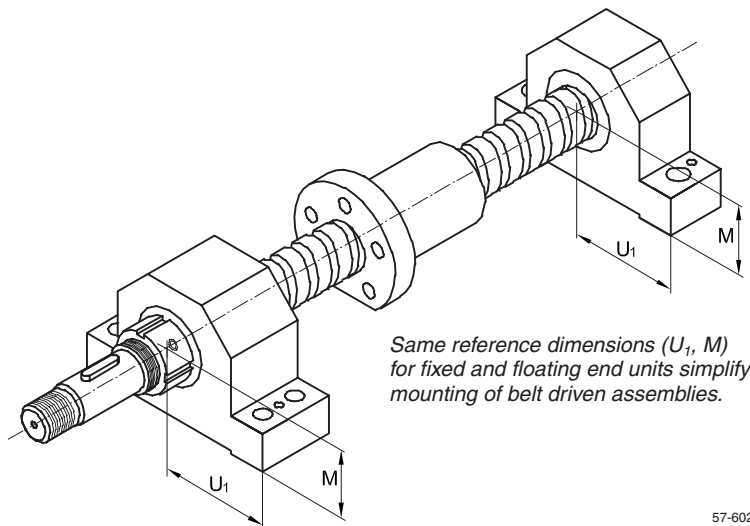

Longer fixed end units with space for integrated coupling and hole pattern for motor mounting on demand.

11.0 Introduction IBC Precision Locknuts and Labyrinth Seals

Fields of application

IBC Precisions Locknuts with fine thread are used for high-precision application. Due to integrated safety systems in the various locknuts, an easy and precise mounting, as well as safeguarding of locknuts is guaranteed.

Installation of lockwashers within an axial groove is no longer necessary. The material cross section is maintained and the notch effect is not increased. Additionally axial precision is enhanced.

Tolerances

A high accuracy of the axial eccentricity according to IT3, ISO basic tolerances according to DIN 7151, will be achieved by precision-machining the inner thread with its locking device and the face in one operation.

These locking devices, which are also profiled, bear on the thread flanks. The thread is manufactured with a tolerance of 4H according to DIN 13 T21-24 and from M210x4 on the tolerance is 6H.

Design

For compact applications (lightest weight), series MMR Precision Locknuts are used. The Precision Locknuts in recessed locations which cannot be reached radially (housing bores) are secured using the axially accessible socket set screws on the MMA, MBA and MBC series.

This option requires a larger width because of the inner construction. From Ø 20 on, the MBA model is supplied. The permissible axial load corresponds to the MMR Precision Locknut. In the range of Ø 45 ... 200 mm also the Precision Locknut MBC with four axial securable socket head cap screws at its end are produced.

The same cross section as for the MBA and MBC is used for the MMRB with radial securing system. The later permits larger loads and tightening torques. This is favorable in particular for preloading bearings supporting a high axial load (in ball screws, for instance).

Precision Locknuts with Labyrinth Seal

The MMRBS and MBAS series additionally have a set of laminar rings made out of spring steel, which may create a compact labyrinth seal in conjunction with the housing where limited space is available. The intermediate space of the labyrinth area must be filled with grease before and after mounting.

The cross section of the series MMRS Precision Locknuts with similar properties as MMRBS Precision Locknuts were designed to match the series BS 60° Super Precision Angular Contact Thrust Ball Bearings and the MD Seal Nuts (see page 62, 63). These are available in the standard sizes as well as in special sizes (different cross section) or made of stainless steel or with ATCoat.

Abutment and Fillet Dimensions

The recommended tolerance of the counter thread of the shaft is "medium" 6g, 6h or "fine" 4h for higher accuracy requirements (machine tools).

Strength of the Precision Locknut Threads

Threads up to M50: 1000 N/mm²
Threads M50 and larger: 650 N/mm²

The permissible axial loads are applicable to bolt threads with a tensile strength of at least 700 N/mm². In case of dynamic load, 75 % of axial load Fa is permissible.

Mounting

Precision Locknut should be screwed on the shaft with all locking devices in unchanged position. Use spanners to tighten the locknuts with approximately triple of the nominal torque (to avoid setting of the clamped parts, loosen and retighten them applying the nominal torque).

Tightening of the locking devices lightly increases the axial forces of precision locknuts of MBA design. The effect of the MBC designed Precision Locknut is contrary and must not be used for bearings with grounded preload. The necessary tightening torque depends on the required preload of the bearings and the required pressfit between the inner rings and the shaft. Additional information see TI-I-5020.0/E page 8 and 9.

Securing against loosening

Lightly tighten the first socket set screw until you notice resistance. Tighten second screw located opposite. If existing, tighten third screw (only in case of MMRB, MMRBS and MMRS) as well as fourth screw in case of version ...Q. Retighten the screws. For maximum tightening torques of the socket set screws and socket head cap screws, please refer to the following table.

Securing thread	Spanner size [mm]		Max tightening torque M _A [Nm]	
	S	S _{MBC}	socket set screws	socket head cap screws
M4	2	3	2	4.5
M5	2.5	4	4	8.5
M6	3	5	7	15
M8	4	6	18	36
M10	5	—	34	—
M12	6	—	60	—

Table: Maximum tightening torques of securing devices in Precision Locknuts

58-704

This results in high loosening torques to prevent unintended loosening even for spindles running clockwise and counter-clockwise intermittently as well as for high speed acceleration of spindle.

Disassembly

Loosen locking devices first for disassembly. As clamping does not deform the profiled securing elements made from hard bronze, the nut can be used repeatedly after loosening.

Designation for IBC Precision Locknuts and Labyrinth Seals

MMR	narrow Precision Locknut with radial lock
MMRB	wide Precision Locknut with radial lock
MMRBS	the same as MMRB, but with laminar Labyrinth Seal
MBA	Precision Locknut with axial lock via slotted segments
MBAS	the same as MBA, but with laminar Labyrinth Seal
MBC	Precision Locknut with axial lock via slotted segments and four screws
MMA	Precision Locknut with axial lock via 2 cones
MMRS	special locknut with radial lock, to match 60° super precision angular contact thrust ball bearings BS and MD Locknut
MD	Seal Nut with fine outer thread, fits to Labyrinth Seals S and MMRS nut
S	Precision Labyrinth Seal with laminar rings made of spring steel
... Q	4 securing elements, unless standard

11.1 IBC Precision Locknuts MMR, MMRB, MMRBS, MMA, MBA, MBAS, MBC

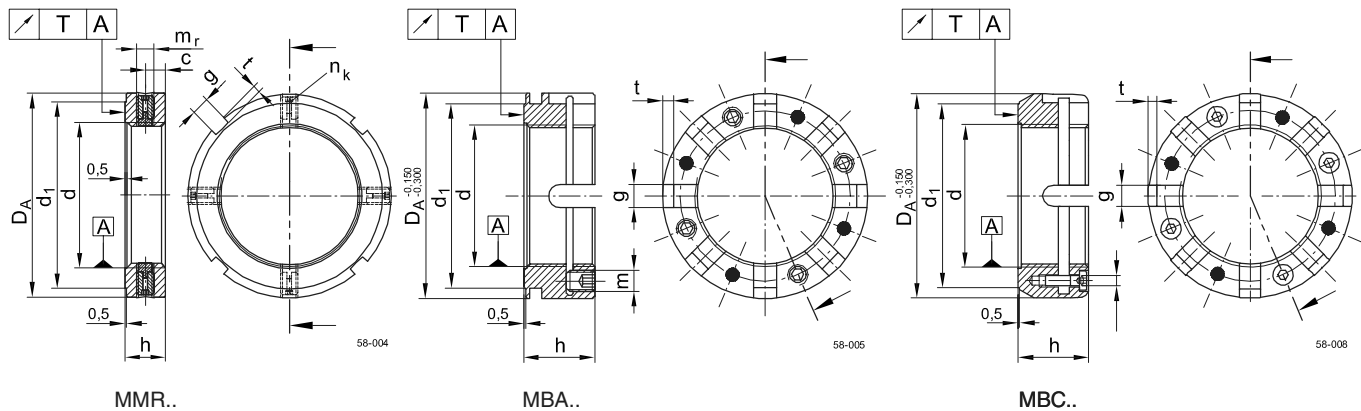

Thread	Designation	Dimensions													Max. tightening torque set screws M_s			Permissible axial load			
		D_A	h	g	t	d_1	c	m_a	m_r	m_c	h_1	h_2	E^{**}	MMR	MBA	MBC	MMR	MMA	MBA	MBC	
		mm													rad.	ax.		F_a			
Tolerance 4H	Radial locking system MMR, MMRB/ MMRBS	Axial locking system MBA/MBAS MBC														Nm			kN		
M 6 x 0.5	MMR 6		16	8	3	2	12	4	-	M 4				-	-	2	-		16		
M 8 x 0.75	MMR 8																	17			
M 10 x 0.75	MMR 10		18				14											22			
M 12 x 1	MMR 12		22				18											26			
M 15 x 1	MMR 15		25				21											33			
M 17 x 1	MMR 17		28	10	4		23	5		M 5					4			49			
	MMA 17 *	16																			M 4
M 20 x 1	MMR 20		32	10			27											55			
	MMRB 20	16																			
M 20 x 1.5	MMR 20 x 1.5			10														70			
	MMRB 20 x 1.5	16																			
M 25 x 1.5	MMR 25		38	12	5		33	6		M 6					7			87			
	MMRB 25	18																			
M 30 x 1.5	MMR 30		45	12			40			M 6			5.2	3.2				110		150	150
	MMRB 30	18																			
M 35 x 1.5	MMR 35		52	12			47											120		170	120
	MMRB 35	18																			
M 40 x 1.5	MMR 40		58	14	6	2.5	52	7										150		210	150
	MMRB 40	20																			
M 45 x 1.5	MMR 45		65	14			59							6	3.6			170		240	170
	MMRB 45	20																			
M 50 x 1.5	MMR 50		70	14			64											180		260	180
	MMRB 50	20																			
M 55 x 2	MMR 55		75	16	7	3	68	8		M 8						18	18	250		340	250
	MMRB 55	22																			
M 60 x 2	MMR 60		80	16			73											270		360	270
	MMRB 60	22																			
M 65 x 2	MMR 65		85	16			78											290		400	290
	MMRB 65	22																			
M 70 x 2	MMR 70		92	18	8	3.5	85	9										350		470	350
	MMRB 70	24																			
M 75 x 2	MMR 75		98	18			90											370		500	370
	MMRB 75	24																			
M 80 x 2	MMR 80		105	18			95						7.3	4.3				390		520	390
	MMRB 80	24																			
M 85 x 2	MMR 85		110	18			102			M 10								400		540	400
	MMRB 85	24																			

Table 58-700: IBC Precision Locknuts MMR, MMRB, MMRBS, MMA, MBA, MBAS, MBC

Further sizes are available on inquiry.

* Securing: 2 cones at 90°

E** see page 60 MMRBS. Special sizes available: MMR 16 x 1.5 Q; MMR 33 x 1.5 Q; MMR 42 x 1.5 Q; MMR 60 x 1.5 Q; MMR 65 x 1.5 Q; MMR 145 x 2 Q.

IBC Precision Locknuts MMR, MMRB, MMRBS, MMA, MBA, MBAS, MBC

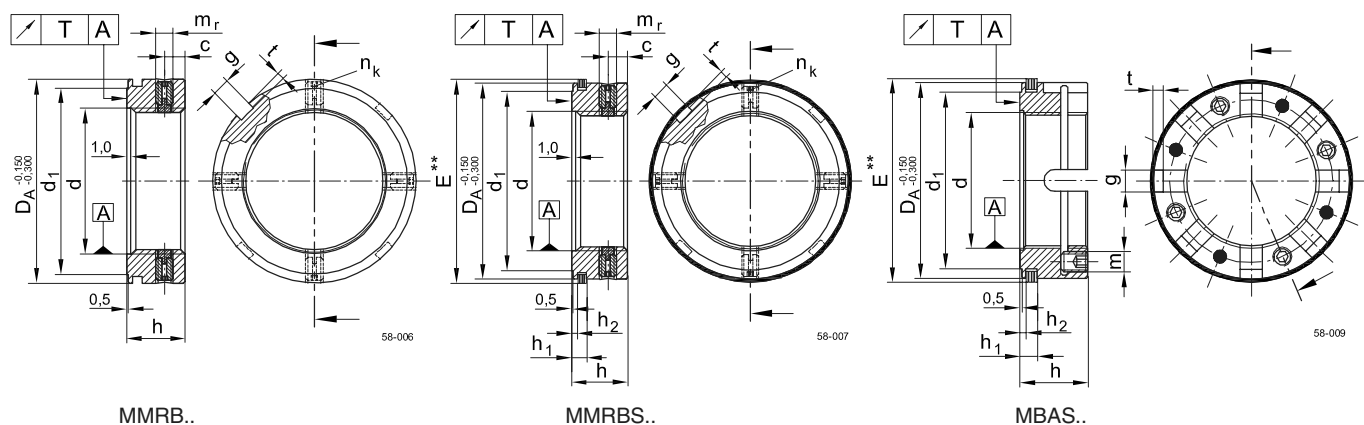

Thread	Designation		Dimensions											Max. tightening torque socket screws M_s		Permissible axial load		
			D_A	h	g	t	d_1	c	m_r m_a	m_c	h_1	h_2	E^{**}	MMR MMRB MBA	MBC	MMR MMA MMRB MBA MBC	F_a	
Tolerance* 4H	Radial locking system MMR, MMRB/ MMRBS	Axial locking system MBA/MBAS MBC	mm											Nm		kN		
M 90 x 2	MMR 90		120	20	10	4	108	9	M 10			7.3	4.3		34		470	
	MMRB 90	MB__ 90		26							M 6			120	15	610	470	
M 95 x 2	MMR 95		125	20			113										490	
	MMRB 95	MB__ 95		26										125		640	490	
M 100 x 2	MMR 100		130	20			120										510	
	MMRB 100	MB__ 100		26										130		660	510	
M 105 x 2	MMR 105		140	22	12	5	126										560	
	MMRB 105	MB__ 105		28										140		700	560	
M 110 x 2	MMR 110		145	22			133										600	
	MMRB 110	MB__ 110		28										145		770	600	
M 115 x 2	MMR 115		150	22			137					7.5	4.4				660	
	MMRB 115	MB__ 115		28										150		820	660	
M 120 x 2	MMR 120		155	24			138										710	
	MMRB 120	MB__ 120		30										155		890	710	
M 125 x 2	MMR 125		160	24			148										740	
	MMRB 125	MB__ 125		30										160		920	740	
M 130 x 2	MMR 130		165	24			149										760	
	MMRB 130	MB__ 130		30						M 8				165	36	950	760	
M 140 x 2	MMR 140		180	26	14	6	160	10	M 12						60		880	
	MMRB 140	MB__ 140		32										180		1 080	880	
M 150 x 2	MMR 150		195	26			171										930	
	MMRB 150	MB__ 150		32										195		1 040	930	
M 160 x 3	MMRB 160	MB__ 160	205	34	16	7	182					8.3	5.3	205		1 360	1 020	
M 170 x 3	MMRB 170	MB__ 170	220				198							220		1 430	1 075	
M 180 x 3	MMRB 180	MB__ 180	230	36	18	8	203							230		1 600	1 200	
M 190 x 3	MMRB 190	MB__ 190	240				214							240		1 670	1 250	
M 200 x 3	MMRB 200	MB__ 200	250	38			226							250		1 850	1 390	
M 210 x 4	MMRB 210		270	40	20	10	238	14	M 14			10	6.4	270	85	2 000		
M 220 x 4	MMRB 220		280				250							280		2 250		
M 240 x 4	MMRB 240		300	44			270							300		2 300		
M 260 x 4	MMRB 260		310				290							310		2 500		
M 280 x 4	MMRB 280		330	50	24		310					11	6.6	330		2 850		
M 300 x 5	MMRB 300		360				336							360		3 100		

Table 58-701: IBC Precision Locknuts MMR, MMRB, MMRBS, MMA, MBA, MBAS, MBC

Further sizes are available on inquiry.

Face runout T acc. to IT3, DIN 7151; *above $\varnothing 200$: 6H

n_k : no. of securing devices = 4

MBAS, MMRBS = MBA, MMRB + Laminar spring steel rings (labyrinth seal)

E^{**} = Bore diameter of counterpart = $D_{A+0}^{+0.1}$... and a 25° chamfer for the sealing (see also MMRB), where the feeding diameter is 4 % larger than D_A .

11.2 IBC Precision Labyrinth Locknuts MMRS

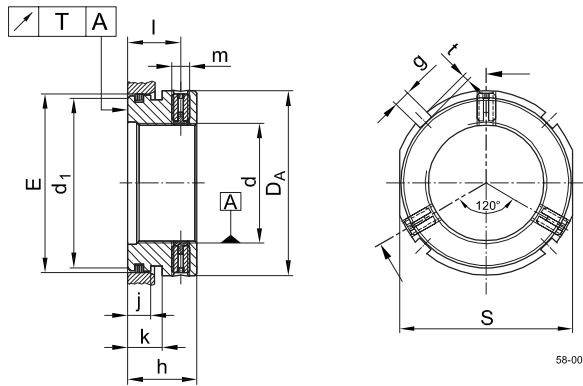

MMRS...Q2

Thread	Designation	Dimensions												Tightening torque set screws M _S Nm	Permissible axial load F _a kN
		E	D _A	h	g	t	d ₁	l	m	j	k	N	S		
		mm													
M 17 x 1	MMRS 17-36.Q2	36	38	20	5	2	32	15.5	M 5	9	11	37.5	36	4	100
M 20 x 1	MMRS 20-36.Q2														110
M 22 x 1	MMRS 22-36.Q2														110
M 25 x 1.5	MMRS 25-50.Q2	50	58	25	6	2.5	46	19	M 6	10	13	52	55	7	150
M 27 x 1.5	MMRS 27-50.Q2														
M 30 x 1.5	MMRS 30-50.Q2														180
M 30 x 1.5	MMRS 30-60.Q2	60	70	28			56	21	M 8			63	65	18	180
M 35 x 1.5	MMRS 35-60.Q2														190
M 40 x 1.5	MMRS 40-60.Q2														210
M 45 x 1.5	MMRS 45-60.Q2														260
M 35 x 1.5	MMRS 35-76.Q2	76	80	30	7	3	72	23			15	79.5	75		290
M 40 x 1.5	MMRS 40-76.Q2														340
M 45 x 1.5	MMRS 45-76.Q2														400
M 50 x 1.5	MMRS 50-76.Q2														420
M 55 x 2	MMRS 55-76.Q2														450
M 55 x 2	MMRS 55-99.Q2	99	105		8	3.5	95					103	95		450
M 60 x 2	MMRS 60-99.Q2														480
M 65 x 2	MMRS 65-99.Q2														480
M 75 x 2	MMRS 75-99.Q2														510
M 100 x 2	MMRS 100-132.Q2	132	140	35	12	5	128	27	M 10	12	19	137.3	135	34	710
M 125 x 2	MMRS 125-162.Q2	162	175				158					165	165		800

Table 58-702: IBC Precision Labyrinth Locknuts MMRS

Further sizes are available on inquiry.

Axial runout T according to IT3, DIN 7151

The Precision Labyrinth Locknut with the mounted lamina spring-steel rings are forming a non-contact seal with an adjusted housing or with a MD series Seal Nut (see page 63 and 64).

Whereas the Labyrinth Locknut is rotating with the shaft, the spring steel rings are not rotating. They are preloaded radially by the internal diameter of the housing or by the MD Seal Nut. The free space has to be filled with the same

grease as used for the bearings. The sealing area of the Precision Labyrinth Locknut is already lubricated with BearLub GH62 grease, which has proven its quality in the lubrication of Ball Screw Support Bearings.

Two parallel wrench surfaces located opposite each other facilitate the assembly. This Precision Locknut is used in particular with 60° Super Precision Angular Contact Thrust Ball Bearings* and in bearing units.

*See hereto also the catalogue TI-1-5010.2/E.

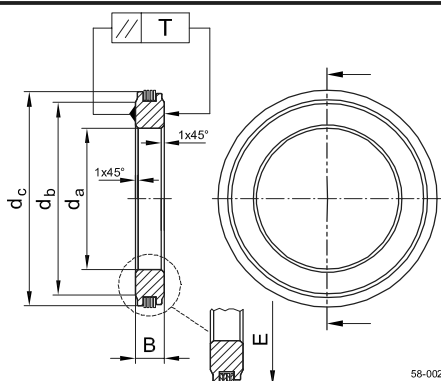

58-002

S...Q2

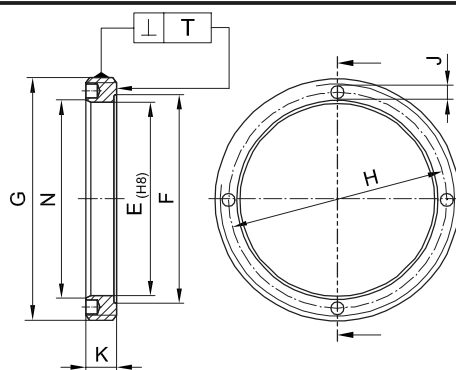

58-003

MD...Q5

Designation	Dimensions				Designation	Dimensions							Permissible axial load F _a kN
	d _a	d _b	d _c	B		E	F	G	H	J	K	N	
	mm					mm							
S 12-26.Q2	12	21	25.6	7	MD 40-26.Q5	26	28	M 40 x 1.5	31	4.3	9	27	45
S 15-26.Q2	15												
S 17-36.Q2	17	26	35.6		MD 50-36.Q5	36	41	M 50 x 1.5	42.5		10	37.5	65
S 20-36.Q2	20												
S 25-40.Q2	25	32	39.7		MD 55-40.Q5	40	45	M 55 x 1.5	47			42	77
S 25-50.Q2		41	49.6	10	MD 70-50.Q5	50	56	M 70 x 1.5	59.5		12	52	100
S 30-50.Q2	30												
S 30-60.Q2		46	59.6		MD 80-60.Q5	60	65	M 80 x 1.5	72			63	130
S 35-60.Q2	35												
S 35-76.Q2		66	75.6	12	MD 110-76.Q5	76	92	M 110 x 2	90	6.3	14	79.5	190
S 40-60.Q2	40	50	59.6	10	MD 80-60.Q5	60	65	M 80 x 1.5	72	4.3	12	63	130
S 40-76-10.Q2		66	75.6		MD 95-76.Q5	76	82	M 95 x 2	84.5	6.3		79.5	150
S 40-76-12.Q2				12	MD 110-76.Q5		92	M 110 x 2	90		14		190
S 45-60.Q2	45	55	59.6	10	MD 80-60.Q5	60	65	M 80 x 1.5	72	4.3	12	63	130
S 45-66.Q2			65.6		MD 85-66.Q5	66	72	M 85 x 1.5	76			69	130
S 45-76.Q2		66	75.6	12	MD 110-76.Q5	76	92	M 110 x 2	90	6.3	14	79.5	190
S 50-76-10.Q2	50	68		10	MD 95-76.Q5		82	M 95 x 2	84.5		12		150
S 50-76-12.Q2				12	MD 110-76.Q5		92	M 110 x 2	90		14		190
S 55-76.Q2	55			10	MD 95-76.Q5		82	M 95 x 2	84.5		12		150
S 55-99.Q2		86	98.6	12	MD 130-99.Q5	99	110	M 130 x 2	110		14	103	220
S 60-99.Q2	60												
S 75-99.Q2	75			10	MD 120-99.Q5		101	M 120 x 2					210
S 100-132.Q2	100	114	131.6	14	MD 160-132.Q5	132	134	M 160 x 3	148		18	137.3	340
S 110-132.Q2	110	120	131.7										
S 127-162.Q2	127	144	161.6	14.5	MD 190-162.Q5	162	167	M 190 x 3	176			166	440

Table 58-703: IBC Precision Labyrinth Seals S and IBC Seal Nuts MD

Further sizes are available on inquiry.

The non-contact series S sealing elements consist of a parallel ground steel ring with a radial outside groove. A set of lamina spring-steel rings is assembled into the groove, surrounded by a grease pack (GH62). They could be pressed into the bore of the matching series MD Seal Nut or into the internal diameter of the housing or are radially preloaded by the outer diameter of the spring steel rings. The support ring of the Labyrinth Seal located on the shaft does not touch the spring rings, which are fixed on the outside diameter.

A grease pack in the groove prevents the axial contact of the lamella with the side faces of the support ring. The parallelism of the support rings $T \leq 2 \mu\text{m}$ used for the Labyrinth Seals are an excellent element between precision locknuts and bearings (Angular Contact Ball Bearings and 60° Super Precision Angular Contact Thrust Ball Bearings) in order to preload them. The Seal Nuts MD with outside thread can also be used separately to clamp the outer rings of bearings or other machine parts. They need to be secured by glue. An external radial lock can be applied via a pin or a screw through the housing.

11.3 Applications of IBC Precision Locknuts and Labyrinth Seals

1. Preloading of a cutting spindle

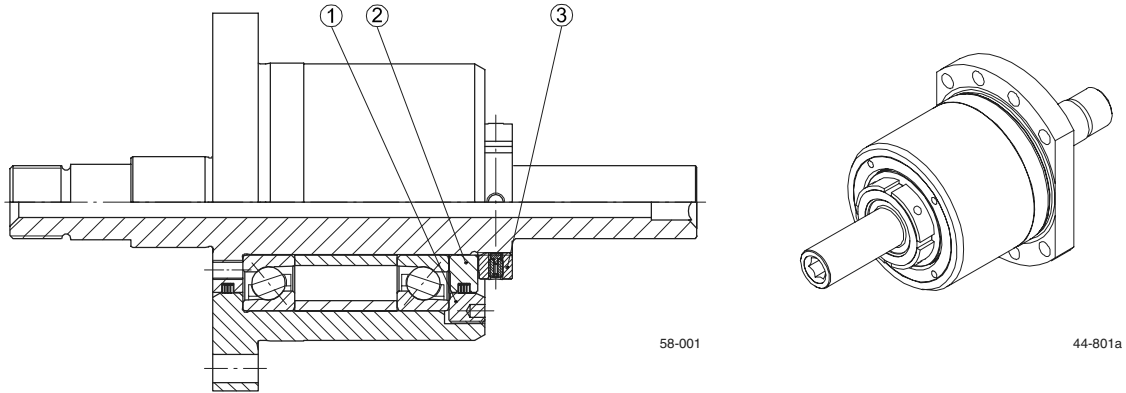

- ① Seal Nut MD 80-60.Q5
- ② Labyrinth Seal S 35-60.Q2
- ③ Precision Locknut MMR 35

2. Ball screw supported at both ends, spring preloaded with Labyrinth Seals and securable Precision Locknuts

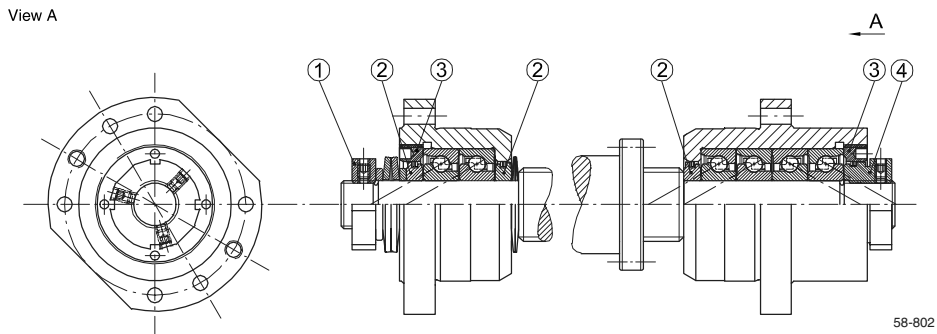

- ① Precision Locknut MMR 40
- ② Labyrinth Seal S 40-60.Q2
- ③ Seal Nut MD 80-60.Q5
- ④ Labyrinth Locknut MMRS 40-60.Q2

3. Preloading bearings at a spindle in pumps

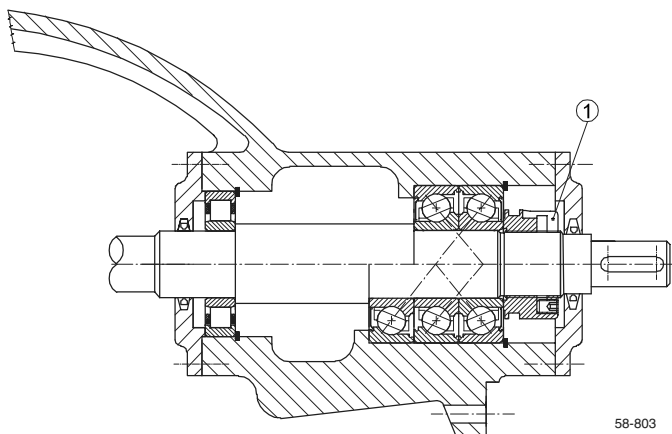

- ① Precision Locknut MBA 30

4. Adjustment of the radial play of a cylindrical roller bearing with a tapered bore via spacers

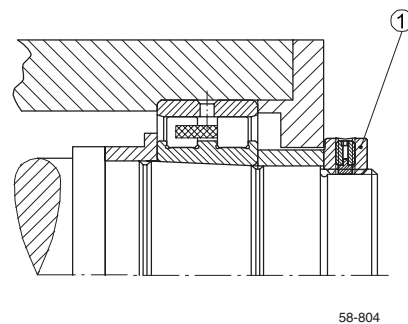

- ① Precision Locknut MMR 100

12. IBC Precision Bearings with ATCoat

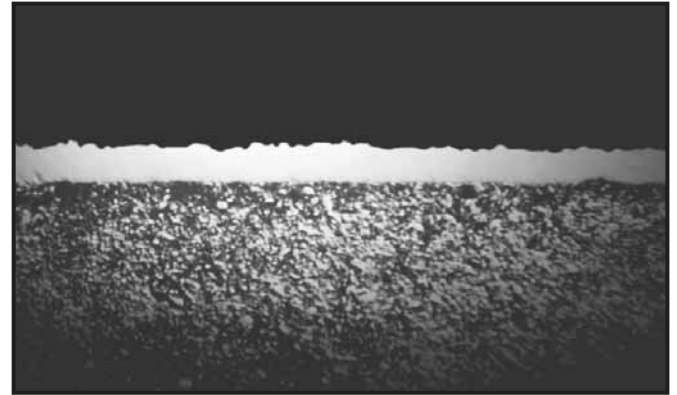

Cross section of ATCoat

Coated bearings

The ATCoat enables a bearing to be higher resistant against corrosion, wear and allows an increase of speed. This is caused by thin dense chromium coat. The special topographic surface also increases the ability of a bearing to withstand emergency situations. All these abilities lead to use coated IBC bearings under uncomfortable lubrication circumstances.

These conditions are for example as explained below:

- when it is impossible to use a lubricant.
- when it is only possible to use a low viscous lubricant which can not create a separating film.
- when the movement is not a complete rotation, where the lubricant film will not remain.
- when the bearing is unloaded and starts to slide.
- when the lubrication of the bearing is under the circumstance that acceleration or braking bring the rolling elements into slide.

The ATCoat coated bearings are an opportunity to corrosion resistant bearings. It can compete especially with those on the functional surfaces.

The coating thickness is about 2–4 μm and the microscopical structure of the surface is ball headed. A combination with ceramic balls lead to very good abilities under extreme conditions.

Purposes of ATCoat

Reduction of friction

Combination of materials	static friction (dry) [μo]	sliding friction (dry) [μ]
Steel/Steel	0.25	0.18
Steel/ATCoat	0.17	0.15
ATCoat/ATCoat	0.14	0.12

- Better adhesion of lubricant film
- Separation of similar materials
- Reduction of friction welding caused by adhesion
- Reduction of fretting corrosion
- Saving of the sliding abilities from inner and outer ring against attached parts (floating bearings)
- Protection of the bearing against intruding corrosion caused by aggressive materials (tribooxidation)
- Wear protection caused by higher hardness of the coat (78–80 HRC; 1300–1400 HV)

Prefixes of ATCoat bearings

- AC- Inner and outer ring ATCoated
- ACC- Rolling elements Si_3N_4 + ATCoat

Suffixes of ATCoat coated bearings

- A11 Inner and outer ring ATCoated
- A15 Inner and outer ring ATCoated, rolling elements and cage corrosion resistant
- A21, A26 Inner ring ATCoated
- A31 Outer ring ATCoated

13. Design Version of IBC Precision Bearing Cages

Precision Angular Contact Thrust Bearings
and Single Row Deep Groove Ball Bearings

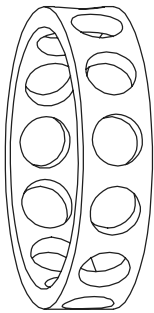

T (PA)
M (PA)
K (PA)



THB
SHA
SHB

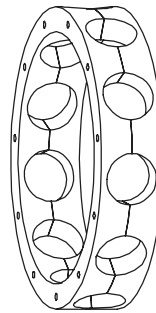

TA
TB

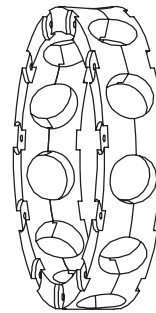

M
MA
MB
LA
LB

51-103

Cylindrical Roller Bearings

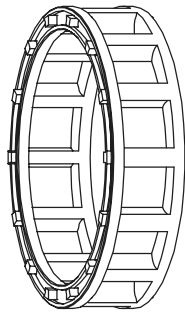

M
M1
MA
M1A

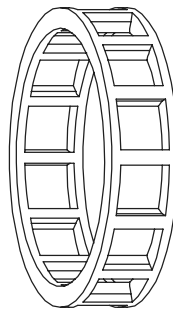

P

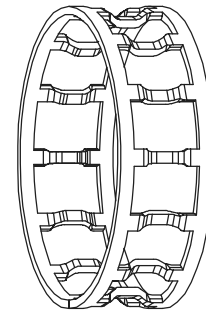

J

52-104

Precision Cylindrical Roller Bearings

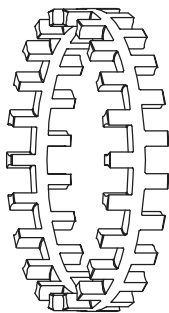

M

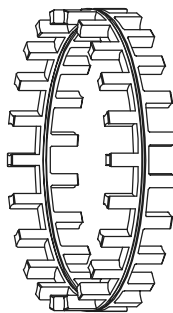

M

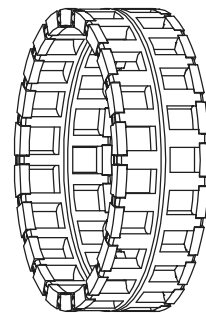

P

52-103

Angular Contact Ball Bearings 40°; 60°

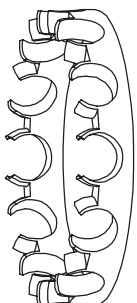

PH
KH

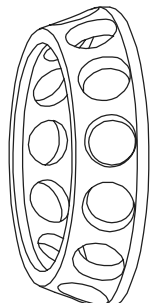

M



P

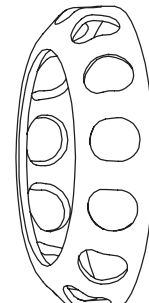

J

44-106

13.1 Characteristics and features of Bearing Cages

IBC suffix	Material	Centring of cage	Cage design	Speed classification* $d_m \cdot n$	Cage factor n_k	Temp.*** °C	Misalignment (except spherical roller bearing)	Speed	Vibration	Lubrication (always necessary)
(J) JL/JN	steel plate	roller guided	ribbon cage riveted cage	0.65	1	300	danger of breaking	danger of breaking	limited	due to steel, very important
JH	steel plate	roller guided	snap cage	0.65	1	220 (300)	limited usability	limited	limited	due to steel, very important
JW	steel plate	roller guided	window type cage	0.65	1	300	limited usability	limited	good	important
M	brass	roller guided	riveted cage	1.0	1.5	200 (300)	limited usability	limited	good	good index of friction
M1	brass	outer ring guided	riveted cage	1.35	2.1	220 (300)	limited usability	high mech. strength, high inertia	excellent	good index of friction
MA	brass	outer ring guided	window type							
M1A	brass	outer ring guided	window type							
MP	brass	roller guided	solid window type cage	1.1	0.75**	220 (300)	limited usability	high mech. strength, high inertia	excellent	good index of friction
MPB	brass	inner ring guided	solid window type cage	1.2	1.9	220 (300)	limited usability	insufficient flexibility	excellent	good index of friction
M (MPA)	brass	outer ring guided	solid window type cage	1.3	0.85**	220	limited usability	good	good	good index of friction
TA	fabric-reinforced phenolic resin	outer ring guided	two-piece riveted cage	1.5	2.4	120	not recommendable	excellent	good	excellent index of friction
TB	fabric-reinforced phenolic resin	inner ring guided	two-piece riveted cage	1.4	2.2	120	not recommendable	excellent	good	excellent index of friction
THB	fabric-reinforced phenolic resin	inner ring guided	snap cage	<1	1.5	120	limited usability	excellent	good	good index of friction
T (TPA)	fabric-reinforced phenolic resin	outer ring guided	solid window type cage	see catalogue		120 (150)	limited usability	excellent high mech. strength	low inertia, well balanced	excellent index of friction
P	polyamide PA6.6 glass fibre reinforced	roller guided	window type cage extruded	see catalogue	2.1	120* 140*	recommendable	very good, high elasticity	excellent high elasticity	good index of friction
PH	polyamide PA6.6 glass fibre reinforced	roller guided	snap cage	1.4	2.1	140 (160)	elastic behaviour	good	very good	good index of friction
K (KPA)	PEEK	outer ring guided	solid window type cage	see catalogue		120* 140* (160)	recommendable	very good, high elasticity	excellent high elasticity	good index of friction
KH	PEEK	roller guided	snap cage	1.4	2.1	120 (160)	elastic behaviour	good	very good	good index of friction
L	light metal	roller guided	riveted cage	1.2	1.9	200	limited usability	limited	good	good index of friction
LA	light metal	outer ring guided	riveted cage	1.5	2.3	200	not recommendable	high mech. strength	very good	good index of friction
LB	light metal	inner ring guided	riveted cage	1.3	2	200	not recommendable	low flexibility, low inertia	very good	good index of friction
SHA	stainless steel	outer ring guided	snap cage	<1	1.3	200 (250)	not recommendable	high mech. strength, high inertia	good	good index of friction with ceramic balls
SHB	stainless steel	inner ring guided	snap cage	<1	1.3	200 (250)	not recommendable	high mech. strength, high inertia	good	good index of friction with ceramic balls
S (SPA)	stainless steel	roller guided	solid window type cage	see catalogue		200 (250)	limited usability	limited	good	good index of friction with ceramic balls

Table: Characteristics and features of Bearing Cages

14-301

* $\cdot 10^6$ mm/min standard value only for single row deep groove ball bearing at moderate bearing load (<0.05 C) and oil. Please ask for cages out of further materials. By adding of glass, or carbon fibres, as well as graphite, or PTFE components in the cage material a temperature extension up to 260 °C is possible. High stability, ductility and low weight allow for higher rotational speed.

Lubrication with aggressive additives within the oil the cage material can reduce the length of service of a bearing. This could happen mainly under high temperature conditions and in such a case as a preventive measure the temperature should be limited to 100 °C.

** Cages for spindle bearings have higher basic speed ratings.

*** For temperature above 140 °C also the inner and outer rings have to be stabilized.

14. Tolerances of associated parts for Precision Angular Contact Bearings

Accuracy of form for shafts

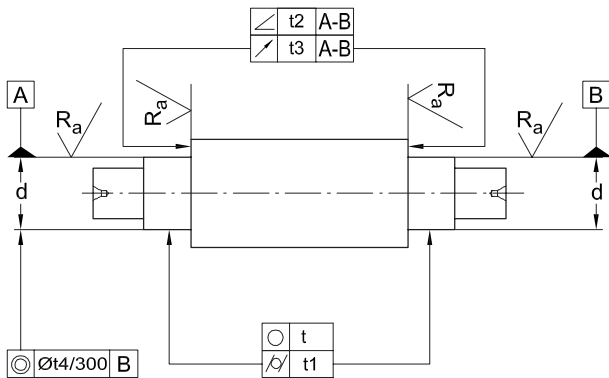

54-602

Accuracy of form for housings

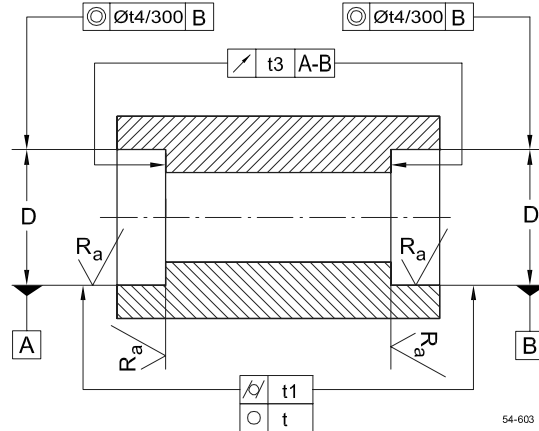

54-603

Characteristic	Tolerance Symbol	Tolerance Designation	Accuracy of form, Tolerance grade, Roughness class for Tolerance class of bearings			
			P6	P5	P4A	P2A
Circularity	\bigcirc	t	$\frac{IT}{2}$	$\frac{IT3}{2}$	$\frac{IT2}{2}$	$\frac{IT1}{2}$
Cylindricity	⌀	t1	$\frac{IT}{2}$	$\frac{IT3}{2}$	$\frac{IT2}{2}$	$\frac{IT1}{2}$
Angularity	\angle	t2	-	-	$\frac{IT3}{2}$	$\frac{IT2}{2}$
Runout	\nearrow	t3	IT4	IT3	IT3	IT2
Coaxiality	\odot	t4	IT6	IT5	IT4	IT3
Roughness R_a						
$d \leq 80$ mm		-	N5	N4	N4	N3
$d > 80$ mm		-	N6	N5	N5	N4

Accuracy of form for shafts

40-306

Characteristic	Tolerance Symbol	Tolerance Designation	Accuracy of form, Tolerance grade, Roughness class for Tolerance class of bearings			
			P6	P5	P4A	P2A
Circularity	\bigcirc	t	$\frac{IT4}{2}$	$\frac{IT3}{2}$	$\frac{IT2}{2}$	$\frac{IT1}{2}$
Cylindricity	⌀	t1	$\frac{IT4}{2}$	$\frac{IT3}{2}$	$\frac{IT2}{2}$	$\frac{IT1}{2}$
Runout	\nearrow	t3	IT4	IT3	IT3	IT2
Coaxiality	\odot	t4	IT6	IT5	IT4	IT3
Roughness R_a						
$D \leq 80$ mm		-	N6	N5	N5	N4
$80 < D \leq 250$		-	N7	N6	N6	N5
$D < 250$ mm		-	N7	N7	N7	N6

Accuracy of form for housings

40-308

ISO Basic Tolerance Grades acc. to DIN 7151									
Nominal Diameter		Tolerance grades							
Over	incl.	IT0	IT1	IT2	IT3	IT4	IT5	IT6	IT7
mm		μm							
6	10	0.6	1	1.5	2.5	4	6	9	15
10	18	0.8	1.2	2	3	5	8	11	28
18	30	1	1.5	2.5	4	6	9	13	21
30	50	1	1.5	2.5	4	7	11	16	25
50	80	1.2	2	3	5	8	13	19	30
80	120	1.5	2.5	4	6	10	15	22	35
120	180	2	3.5	5	8	12	18	25	40
180	250	3	4.5	7	10	14	20	29	46
250	315	4	6	8	12	16	23	32	52
315	400	5	7	9	13	18	25	36	57
400	500	6	8	10	15	20	27	40	63

Basic tolerance grades acc. to DIN 7151

40-309

Roughness R_a of the axial shoulder at shaft, housing or spacers:
 $N6 = 0.8 \mu\text{m}$

Surface roughness Class	Roughness μm
N3	0.1
N4	0.2
N5	0.4
N6	0.8
N7	1.6

Roughness

40-310

15. Radial Clearance values in μm

Radial clearance of IBC deep groove ball bearings

$\varnothing d$ [mm]	over incl.	2.5	6	10	18	24	30	40	50	65	80	100	120	140	160	180	200	225	250	280	315	335
		6	10	18	24	30	40	50	65	80	100	120	140	160	180	200	225	250	280	315	355	400
C2	min	0	0	0	0	1	1	1	1	1	1	2	2	2	2	2	4	4	4	8	8	8
	max	7	7	9	10	11	11	11	15	15	18	20	23	23	25	30	32	36	39	45	50	60
CN	min	2	2	3	5	5	6	6	8	10	12	15	18	18	20	25	28	31	36	42	50	60
	max	13	13	18	20	20	20	23	28	30	36	41	48	53	61	71	82	92	97	110	120	140
C3	min	8	8	11	13	13	15	18	23	25	30	36	41	46	53	63	73	87	97	110	120	140
	max	23	23	25	28	28	33	36	43	51	58	66	81	91	102	117	132	152	162	180	200	230
C4	min		14	18	20	23	28	30	38	46	53	61	71	81	91	107	120	140	152	175	200	230
	max		29	33	36	41	46	51	61	71	84	97	114	130	147	163	187	217	237	260	290	330
C5	min		20	25	28	30	40	45	55	65	75	90	105	120	135	150	175	205	225	260	290	330
	max		37	45	48	53	64	73	90	105	120	140	160	180	200	230	255	290	320	360	405	460

Radial clearance of cylindrical roller bearings and needle roller bearings, single row and double row with cylindrical bore

$\varnothing d$ [mm]	over incl.	-	24	30	40	50	65	80	100	120	140	160	180	200	225	250	280	315	335	400	450	500
		24	30	40	50	65	80	100	120	140	160	180	200	225	250	280	315	355	400	450	500	560
C1	min		5	5	5	5	10	10	10	10	10	10	15	15	15	20	20	20	25	25	25	25
	max		15	15	18	20	25	30	30	35	35	40	45	50	50	55	60	65	75	85	95	105
SPC2X	min		8	12	14	17	18	20	25	30	35	35	40	45	45	50	55	60	70	75	90	100
	max		23	25	30	35	38	40	45	50	65	70	75	85	100	110	120	130	145	165	185	205
C2	min	0	0	5	5	10	10	15	15	15	20	25	35	45	45	55	55	65	100	110	110	120
	max	25	25	30	35	40	45	50	55	60	70	75	90	105	110	125	130	145	190	210	220	240
CN	min	20	20	25	30	40	40	50	50	60	70	75	90	105	110	125	130	145	190	210	220	240
	max	45	45	50	60	70	75	85	90	105	120	125	145	165	175	195	205	225	280	310	330	360
C3	min	35	35	45	50	60	65	75	85	100	115	120	140	160	170	190	200	225	280	310	330	360
	max	60	60	70	80	90	100	110	125	145	165	170	195	220	235	260	275	305	370	410	440	480
C4	min	50	50	60	70	80	90	105	125	145	165	170	195	220	235	260	275	305	370	410	440	480
	max	75	75	85	100	110	125	140	165	190	215	220	250	280	300	330	350	385	460	510	550	600
C5	min	75	75	85	100	110	125	140	165	190	215	220	250	280	300	330	350	385	460	510	550	600
	max	100	100	110	130	140	160	175	205	235	265	270	305	340	365	400	425	465	550	610	660	720

Radial clearance of cylindrical roller bearings and needle roller bearings, single row and double row with tapered bore

$\varnothing d$ [mm]	over incl.	-	24	30	40	50	65	80	100	120	140	160	180	200	225	250	280	315	335	400	450	500
		24	30	40	50	65	80	100	120	140	160	180	200	225	250	280	315	355	400	450	500	560
C1X	min		5	5	5	5	10	10	10	10	10	10	15	15	15	20	20	20	25	25	25	25
	max		15	15	18	20	25	30	30	35	35	40	45	50	50	55	60	65	75	85	95	105
C1	min		15	15	17	20	25	35	40	45	50	55	60	60	65	75	80	90	100	110	120	130
	max		25	25	30	35	40	55	60	70	75	85	90	95	100	110	120	135	150	170	190	210
SPC2X	min		15	16	18	20	25	33	40	45	50	55	60	65	70	75	80	90	100	110	120	130
	max		25	27	30	35	45	52	60	68	75	85	90	95	100	110	120	135	150	170	190	210
C2	min	15	20	20	25	30	35	40	50	55	60	75	85	95	105	115	130	145	165	185	205	230
	max	40	45	45	55	60	70	75	90	100	110	125	140	115	170	185	205	225	255	285	315	350
CN	min	30	35	40	45	50	60	70	90	100	110	125	140	155	170	185	205	225	255	285	315	350
	max	55	60	65	75	80	95	105	130	145	160	175	195	215	235	255	280	305	345	385	425	470
C3	min	40	45	55	60	70	85	95	115	130	145	160	180	200	220	240	265	290	330	370	410	455
	max	65	70	80	90	100	120	130	155	175	195	210	235	260	285	310	340	370	420	470	520	575
C4	min	50	55	70	75	90	110	120	140	160	180	195	220	245	270	295	325	355	405	455	505	560
	max	75	80	95	105	120	145	155	180	205	230	245	275	305	335	365	400	435	495	555	615	680
C5	min	75	80	95	105	120	145	155	180	205	230	245	275	305	335	365	400	435	495	555	615	680
	max	100	105	120	135	150	180	190	20	250	280	295	330	365	400	435	475	515	585	655	725	800

Table: Radial clearance

16. Tolerances of Radial Bearings

Data table in μm

	Inner ring [mm]	Precision	\varnothing 0.6	10	18	30	50	80	120	150	180	250
			to 10	18	30	50	80	120	150	180	250	315
Δd_{mp}	Max. deviation of the mean bore diameter from the nominal	PN	-8	-8	-10	-12	-15	-20	-25	-25	-30	-35
		P6	-7	-7	-8	-10	-12	-15	-18	-18	-22	-25
		SP, P5	-5	-5	-6	-8	-9	-10	-13	-13	-15	-18
		P4	-4	-4	-5	-6	-7	-8	-10	-10	-12	-15
		P4A, P2H	-4	-4	-4	-5	-5	-6	-7.5	-7.5	-10	-13
		P2A	-2.5	-2.5	-2.5	-2.5	-3.8	-5.1	-6.4	-6.4	-7.5	-
K_{ia}	Radial runout of assembled bearing inner ring	PN	10	10	13	15	20	25	30	30	40	50
		P6	6	7	8	10	10	13	18	18	20	25
		SP	-	-	3	4	4	5	6	6	8	-
		P5	4	4	4	5	5	6	8	8	10	13
		P4	2.5	2.5	3	4	4	5	6	6	8	-
		P4A	2.5	2.5	2.5	4	4	5	6	6	7.5	10
		P2H	2	2	2.5	2.5	2.5	2.5	2.5	2.5	5	5
		P2A	1.3	1.3	2.5	2.5	2.5	2.5	2.5	5	5	-
S_d	Side face runout referring to bore of inner ring	SP, P5	7	7	8	8	8	9	10	10	11	13
		P4	3	3	4	4	5	5	6	6	7	-
		P4A	2	2	2	2	2	3	3	4	5	10
		P2H	1.5	1.5	1.7	1.8	2	2.5	2.5	4	5	6
		P2A	1.3	1.3	1.3	1.3	1.3	2.5	2.5	3.8	3.8	-
S_{ia}	Side face runout with reference to the raceway of the assembled bearing inner ring	SP, P5	7	7	8	8	8	9	10	10	15	15
		P4	3	3	4	4	5	5	7	7	8	-
		P4A	2.5	2.5	4	4	4	5	7	7	7.5	10
		P2H	2	2	2.5	2.5	2.5	3.5	5	6	6.5	7
		P2A	1.3	1.3	2.5	2.5	2.5	2.5	2.5	5	5	-
ΔB_s	Deviation of single inner ring width	PN, P6	-120	-120	-120	-120	-150	-200	-250	-250	-300	-350
		SP, P5, P4	-40	-80	-100	-120	-150	-200	-250	-250	-300	-350
		P4A, P2H, P2A	-200	-200	-200	-200	-250	-320	-370	-370	-500	-
V_{Bs}	Ring width variation	PN, P6	15	20	20	20	25	25	30	30	30	35
		SP	-	-	-	5	5	6	7	8	10	-
		P5	5	5	5	5	6	7	8	8	10	13
		P4	2.5	2.5	2.5	3	4	4	5	5	6	-
		P4A	2.5	2.5	2.5	2.5	4	4	5	5	5	8
		P2H	2	2	2	2	3	3	4	4	4	-
		P2A	1.3	1.3	1.3	1.3	1.3	2.5	2.5	4	4	-

Table: Tolerances of radial bearings

10-100

To simplify the arrangement of bearing sets and to ease up the combination with assorted tolerances of shafts and housings the grades for O.D. and bore are marked with the mean diameter variation of the reduced tolerance range. The mean deviation is approximately +/- 0.001 mm.

Example: 71907.E.T.P2H.X3.UL
 D= 55.000 – 54.998 mm
 d= 34.997 – 34.995 mm

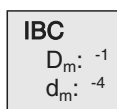

The classification of the allowed tolerance into two or three ranges for the O.D. ΔD_m and bore Δd_m is done according to the sizes of bore and the quality (P4A, P2H, P2A).

Up to a total tolerance of 5 μm there are two ranges, a top and bottom which were marked with T and B are now marked with numerical values of the mean tolerance range.

Bigger size bearings with a total tolerance of more than 5 μm have three ranges.

There are resulting four respectively nine combinations denoted by the symbol X1 to X9.

(See also matrix page 71.)

As far as the graded combination is available it can be delivered. But the bearings are not manufactured especially to a certain X_-category. A selection of this leads to price increase. (Additional information on demand.)

16.1 Tolerances of Radial Bearings

Data table in μm

	Outer ring [mm]	Precision	\varnothing 18	30	50	80	120	150	180	250	315	400	500
			to 30	50	80	120	150	180	250	315	400	500	630
ΔD_{mp}	Max. deviation of mean outside diameter to nominal	PN	-9	-11	-13	-15	-8	-25	-30	-35	-40	-45	-50
		P6	-8	-9	-11	-13	-15	-18	-20	-25	-28	-33	-38
		SP, P5	-6	-7	-9	-10	-11	-13	-15	-18	-20	-23	-28
		P4	-5	-6	-7	-8	-9	-10	-11	-13	-15	-18	-22
		P4A, P2H	-5	-5	-5	-7.5	-9	-10	-10	-13	-13	-15	-
		P2A	-3.8	-3.8	-3.8	-5	-5	-6.4	-7.5	-7.5	-10	-	-
K_{ea}	Radial runout of assembled bearing outer ring	PN	15	20	25	35	40	45	50	60	70	80	100
		P6	9	10	13	18	20	23	25	30	35	-	-
		P5	6	7	8	10	11	13	15	18	20	-	-
		P4, SP	4	5	5	6	7	8	10	11	13	-	-
		P4A	4	5	5	5	7	7.5	10	10	13	13	-
		P2H	2.5	2.5	4	5	5	5	7	7	8	9	11
P2A	2.5	2.5	3.8	5	5	5	6.4	6.4	7.5	-	-		
S_D	Variation in inclination of outside cylindrical surface to outer ring side face	P5, SP	8	8	8	9	10	10	11	13	13	-	-
		P4	4	4	4	5	5	5	7	8	10	-	-
		P4A	4	4	4	5	5	5	7	7.5	10	10	-
		P2H	1.5	1.5	1.5	2.5	2.5	2.5	4	5	7	8	9
		P2A	1.3	1.3	1.3	2.5	2.5	2.5	3.8	3.8	6	-	-
S_{ea}	Side face runout referring to raceway of assembled bearing outer ring	P5, SP	8	8	10	11	13	14	15	18	20	-	-
		P4	5	5	5	6	7	8	10	10	13	-	-
		P4A	5	5	5	5	7	7.5	10	10	13	-	-
		P2H	2.5	2.5	4	5	5	5	7	7	8	10	12
		P2A	2.5	2.5	3.8	5	5	5	6.4	6.4	7.5	-	-

The width tolerance (Δ_{Bs} , Δ_{Cs}) of not universal ground bearings is 50 μm .

The width tolerances of the outer ring (Δ_{Cs} , V_{Cs}) correspond to those of inner ring (Δ_{Bs} , V_{Bs}).

The total width tolerance of a bearing set is the sum of the ones of the single bearings.

Table: Outer ring tolerances

10-101

Grading within the allowed total tolerance

	Total tolerance < 5 μm		Total tolerance > 5 μm	
	Outside diameter Δ_{Dm}	Bore Δ_{dm}	Outside diameter Δ_{Dm}	Bore Δ_{dm}
X1	upper	upper	upper	upper
X2			upper	middle
X3	upper	lower	upper	lower
X4			middle	upper
X5			middle	middle
X6	lower	upper	lower	upper
X7			lower	middle
X8	lower	lower	lower	lower
X9			middle	lower

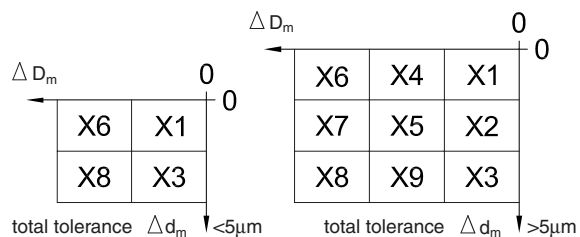

Matrix: Combination of arrangement groups for Δ_{Dm} and Δ_{dm}

40-311

16.2 Tolerances of Thrust Bearings

Shaft washer		Precision	$\varnothing -$ to 18	18 30	30 50	50 80	80 120	120 180	180 250
Δ_{dmp}	Mean bore diameter; arithmetical mean of the largest and smallest bore diameters measured in one plane	PN, P6, P5 P4	- 8 - 7	-10 - 8	-12 -10	-15 -12	-20 - 5	-25 -18	-30 -22
V_{dp}	Bore diameter variation; difference between the largest and smallest single bore diameters in one radial plane	PN, P6, P5 P4	6 5	8 6	9 8	11 9	15 11	19 14	23 17
S_i	Shaft washer thickness variation from raceway middle to back face (axial runout of thrust bearings)	PN P6 P5 P4	10 5 3 2	10 5 3 2	10 6 3 2	10 7 4 3	15 8 4 3	15 9 5 4	20 10 5 4
Housing washer									
Δ_{Dmp}	Deviation of mean outside diameter from nominal dimension	PN, P6, P5 P4	-11 - 7	-13 - 8	-16 - 9	-19 -11	-22 -13	-25 -15	-30 -20
V_{Dp}	Outside diameter variation; difference between the largest and smallest single outside diameters in one radial plane	PN, P6, P5 P4	8 5	10 6	12 7	14 8	17 10	19 11	23 15
S_e	Housing washer thickness variation from raceway middle to back face (axial runout of thrust bearings)	P0 P6 P5 P4	10 5 3 2	10 5 3 2	10 6 3 2	10 7 4 3	15 8 4 3	15 9 5 4	20 10 5 4
Section height									
$\Delta H_s, T_{max}$ T_{min}	Deviation of a single overall thrust bearing height from nominal dimension			20 -250	20 -250	20 -300	25 -300	25 -400	30 -400

Table: Tolerances of thrust bearings

10-102

16.3 Axial Fixation of Bearing Rings

Outer rings of bearings are most often clamped via flanges or retaining plates against a housing wall with socket head cap screws. Especially if bearings of a small cross section are bolted with a small number of screws an inadvertent one-sided fastening may result in an uneven deformation of the outer ring. This may lead to an inclination of the outer ring and results into axial and/or radial runout. See examples.

Tolerating the preload gap between retaining plate and housing to 0.01 ... 0.04 mm and the use of more smaller screws than some bigger ones will help. Fastening of the bolts should be done in a controlled way step by step in a diagonal sequence instead of once with the final torque.

Deformation of the raceway via retaining flange and screws

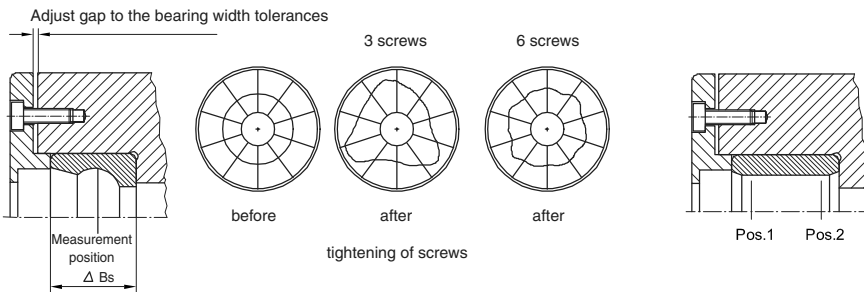

Axial fixation of bearing rings

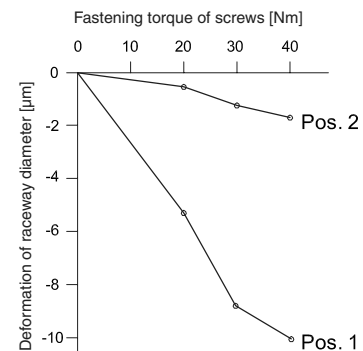

10-200

17. Proposed Fits for Mating Parts of Spindle Bearings [µm]

Nominal diameter d shaft [mm]	Precision	Ø incl.	– 10	10 18	18 30	30 50	50 80	80 120	120 180	180 250
Max. deviation of the mean bore diameter from the nominal Δd_{mp}	P4A		–4	–4	–4	–5	–5	–6	–7.5	–10
	P2H		–3	–3	–3	–4	–4.5	–5.5	–7	–8
	P2A		–2.5	–2.5	–2.5	–2.5	–3.8	–5	–6.4	–7.6
Shaft tolerance	P4A	max.	+2	+2	+2	+3	+3	+3	+3.5	+4
		min.	–2	–2	–2	–2	–2	–3	–4	–6
	P2A	max.	+0.5	+0.5	+0.5	+0.5	+2	+2	+3	+4
		min.	–2	–2	–2	–2	–2	–2	–2	–3
Mean fit on shaft P = pressfit	P4A	mean	P 2	P 2	P 2	P 3	P 3	P 3	P 3.5	P 4
	P2A	mean	P 0.5	P 0.5	P 0.5	P 0.5	P 1.9	P 3	P 3.2	P 3.8

Nominal diameter D housing [mm]	Precision	Ø incl.	18 30	30 50	50 80	80 120	120 150	150 180	180 250	250 315	315 400
Max. deviation of the mean outside diameter to nominal ΔD_{mp}	P4A		–5	–5	–5	–7.5	–9	–10	–10	–13	–13
	P2H		–4	–4	–4	–6	–7	–8	–8	–10	–10
	P2A		–3.8	–3.8	–3.8	–5	–5	–6.4	–7.5	–7.5	–10
Housing tolerance ΔD fixed bearing	P4A	max.	+5	+5	+5	+5	+7	+7	+7	+10	+11
		min.	0	0	0	–2.5	–3	–3	–3	–3	–4
	P2A	max.	+4	+4	+4	+5	+5	+5	+5	+5	+7
		min.	0	0	0	0	0	–1	–2.5	–2.5	–4
Fit for fixed bearing C = clearance	P4A	mean	C 5	C 5	C 5	C 5	C 6.5	C 7	C 7	C 10	C 10
	P2A	mean	C 3.9	C 3.9	C 3.9	C 5	C 5	C 5.2	C 5	C 5	C 6.5
Housing tolerance floating bearing	P4A	max.	+7	+7	+7	+11	+17	+17	+19	+24	+25
		min.	+2	+2	+2	+4	+7	+7	+9	+11	+10
	P2A	max.	+7	+8	+9	+11	+13	+13	+15	+17	+21
		min.	+3	+4	+5	+7	+7	+7	+7.5	+9.5	+10
Fit for floating bearing C = clearance	P4A	mean	C 7	C 7	C 7	C 11	C 16.5	C 17	C 19	C 24	C 24
	P2A	mean	C 6.9	C 7.9	C 8.9	C 11	C 12.5	C 13.2	C 15	C 17	C 20.8

Table: Summary of tolerances for adjacent parts for Super Precision Angular Contact Ball Bearings;
For bearings according to precision class P2H the tolerances of P2A should be chosen

10-300

General information about fits

The selection of an appropriate interference for the shaft will assure a safe fit on the shaft and avoid moving of the inner ring encountering a circumferential load. The fits on shaft and housing influence the clearance or preload within the bearings. Tight fits on shafts will increase the preload in angular contact bearings. For hollow shafts and thin housings tighter fits may be chosen.

High centrifugal forces may ask for tighter fits to the shaft and reduction of preload to zero or even some axial play may be necessary.

Floating end fits must allow for the length variation of shaft or housing after heating up the spindle during operation.

17.1 Proposed Fits for Super Precision 60° Angular Contact Thrust Bearings

Nominal diameter d shaft [mm]	Precision	Ø incl.	– 10	10 18	18 30	30 50	50 80	80 120	120 180
Shaft tolerance Δd_1 fixed bearing	P4A	max.	–3	–3	–3	–4	–4	–5	–6
		min.	–7	–7	–7	–8	–9	–10	–12

Nominal diameter D housing [mm]	Precision	Ø incl.	18 30	30 50	50 80	80 120	120 150	150 180	180 250
Housing tolerance ΔD_G fixed bearing	P4A	max.	+5	+5	+5	+5	+7	+7	+7
		min.	0	0	0	–1	–1	–2	–2

Table: Summary of tolerances for adjacent parts for Super Precision 60° Angular Contact Thrust Bearings.

10-301

18. Lubrication of bearings – IBC BearLub-Greases

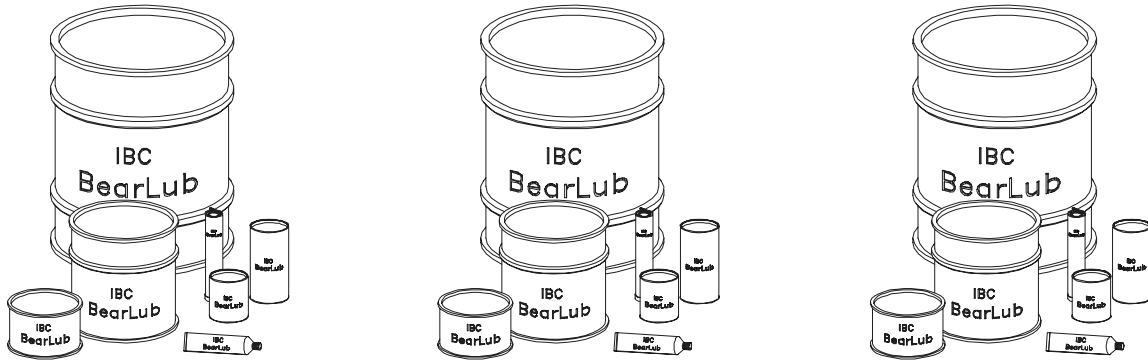

14-001

IBC suffix	Rotational figures dm · n mm/min	Temperature range °C	Consistence classification NLGI	Basic oil	Viscosity of basic oil		Thickener	Density g/cm ³	Comments
					40°C	100°C			
					mm ² /s				
GN 02	0.6	-30/+130	2	Mineral oil	100	10	Li-12 Hydro Stearat	0.9	Standard grease for single row deep groove ball bearings until D=72, noise reduced
GN 03	0.6	-25/+130	3	Mineral oil	100	10	Li-12 Hydro Stearat	0.9	Standard grease for single row deep groove ball bearings above D=72, noise reduced
GN 21	1.0	-35/+140	2	Mineral oil + EP	82	12.5	Li-12 Hydro Stearat	0.87	Multi purpose heavy duty grease for lubrication of guides and stationary housing applications
GS 32	1.0	-50/+120	2	Mineral oil + Ester oil	15	3.7	Li-soap	0.88	Noise tested grease for high rotational speed and low temperatures
GS 34	1.0	-50/+120	2	Mineral oil + Ester oil	21	4.7	Ba-Complex	0.99	High speed and low temperature grease
GS 36	1.8	-40/+120	2/3	PAO Ester	25	6	Li-soap	0.94	Especially for high speed spindle bearings in machine tools
GS 41	1.0	-60/+140	2	SK-Synthetic oil	18	4	Ba-Complex soap	0.96	High speed grease for taper roller bearings
GS 75	>2.0	-50/+120	2	Ester oil + SKW	22	5	Polycarbamide	0.92	Especially for high speed spindle bearings in machine tools
GH 62	0.5	-30/+160	2/3	Ester oil + SKW	150	18	Polycarbamide	0.88	High temperature and long duration
GH 68	1.3	-35/+160	2	Ester oil	55	9	Li-soap	0.975	Grease for high temperature, heavy duty and high speed
GH 70	0.6	-40/+180	2/3	Synthetic	70	9.4	Polycarbamide	0.95	Very low noise, high temperature grease
GH 72	0.7	-40/+180	2/3	Ester oil	100	12	Polycarbamide	0.97	Low noise, life time lubrication, high temperature, corrosion protective
GH 83	0.3	-60/+250	1	Fluoridated Polyester oil	300	85	PTFE	1.94	Highest viscosity during operation under high temperature conditions
GH 88	0.3	-30/+260	2	Perfluoropolyether	55	9	PU	1.7	High thermal and chemical resistance, high performance under pressure, radiation and in vacuum
GH 90	0.6	-50/+260	2	PFPE	190	34	PTFE	1.9	High life time, consistent with most elastomers, good resistance against aggressive chemicals
GA 91	0.3	-75/+260	1/2	Silicon oil			Teflon		Resistance against corrosion and oxidation, used for aircraft industry
GF 20	0.3	-40/+120	1	Mineral oil	230	22	Al-Complex soap	0.9	Good adhesive and wear protection, used for food industry

Table: Lubrication of bearings – IBC BearLub-Greases

14-300

The mentioned speed ratio (medium bearing diameter) of lubricants is a reference value for spring-preloaded bearings of medium diameter. Hybrid bearings allow for higher values (35%), roller bearings and others allow for reduced values.

For further lubricants please ask our Technical Department.